



Summary

- Summary.....1
- BIFLEX2
- Technical Data.....3
- Actual lengths for BIFLEX tracks.....4
- Structure of standard BIFLEX conveyor.....5
- Fundamental characteristics of the chain guide channel.....6
- Chains.....9
- End motor drive12
- Central motor drive20
- Intermediate motor drive on chain return.....24
- How to write the order codes for motor drives.....28
- Standard Returns29
- Safety protection devices on the end drives33
- Curves.....34
- Summarizing table of order codes for curves.....40
- Lateral guides41
- Lateral guides accessories.....47
- Double tracks BIFLEX conveyor52
- Motor drives for double tracks BIFLEX conveyor.....53
- How to write the order codes for motor drives for double tracks BIFLEX conveyor.....58
- Standard returns for double tracks BIFLEX conveyor59
- Summarizing table of order codes for double tracks flat sliding curves.....62
- Conveyor support systems.....63
- How to write the order codes for conveyor support systems69
- Conveyor support accessories.....70
- Stainless Steel BIFLEX77



BIFLEX is a modular system with reduced dimensions suitable for realization of single or double tracks conveyors



Biflex system exploits the versatile chain 1843 type that allows reduced dimensions while maintaining high workload and operating speeds.

Biflex is a conveyor system that allows to use different types of table-top chains in steel and plastic with a width of 31,8 mm, 38,1 mm and 50,6 mm.

Biflex is an Italian product that can offer flexible solutions to a wide range of needs in the product handling process.

Biflex was designed to be easy to use, both by plant and machine builders and by companies that need to handle products.

Biflex is a practical system, that allows to use a vast range of accessories and standard components available on the market.

Biflex interfaces easily with other systems and allows to reuse different elements of related components.



Technical Data*

■ **Product dimensions: 20÷500 mm**

The geometric shape of the product to be handled influences the maximum width of products accommodated by the system. The system can handle products that are up to 5-6 times the chain width, using a double tracks conveyor. In any case, it is better to run trials to find out whether support guides are needed.

■ **Maximum product weight: 30 Kg horizontal transport - 15 Kg vertical transport**

The maximum weight of the product transported is limited to the need to minimize wear and tear of slideways in horizontal transport and flight resistance in vertical transport.

■ **Maximum weight on the conveyor: 450÷500 Kg**

The maximum weight depends essentially on the motor drive's tow capacity, the maximum admissible workload of the chain and the conveyor belt layout.

■ **Maximum conveyor length: 25÷30 m**

The maximum length of the conveyor depends on the total load, the motor drive capacity, the speed and the conveyor layout.

It is important to calculate and compare the maximum chain tension and the motor drive capacity in the following situations:

- Heavy loads
- Accumulation
- Vertical conveyor
- High speed
- Long conveyor
- Conveyor with flat plane curves or vertical curves
- Frequency of starts and stops

■ **Maximum conveyor speed: 80 m/min**

The maximum speed of the conveyor depends on the total load and the motor drive capacity.

■ **Noise level of the conveyor:**

Various factors contribute to making the conveyor noisy:

- Products on the conveyor
- Conveyor speed
- Installation site
- Layout and size of the conveyor

After an initial period of running, the noise from the chain diminishes.

A higher speed will produce more noise.







At high speeds, the wide radius plane curves are quieter than disk curves.

* The data indicated above should be considered indicative of normal conveyor performance. For applications that have values outside of this range or have particular working conditions, please contact our technical office for a feasibility assessment.

Actual lengths for BIFLEX tracks

The following table shows actual layouts of the various components, rounded to the successive 5 mm, in order to determine the quantity of chain needed to make the belt.

For some components, like the curves, the total materials needed are indicated as sums of the individual upper and lower tracks of the curves. Standard curves are made with a straight track of 110 mm on the two ends of the curve itself. The indicated lengths also include this length of track. Therefore, if the track calculation is done by measuring the average distances between curves, you must subtract 110 mm. Standard vertical curves included a 90 mm straight track instead. With tracks that do not have a return track, the track should be added only once. For the straight channel tracks, it is necessary to sum up the lengths of the various elements, doubling the quantity or not, depending on whether or not the return track is needed.

Description	Track length (mm)	Track layout
End drives BIMPD/S - BIMRD/S	765	
Central motor drive BIMCPD/S - BIMCRD/S	1175	
Intermediate motor drive on return chain BIMIPD/S - BIMIRD/S	upper track = 440 lower track = 1155	
180° Long Return BIRL	725	
180° Short Return BIRC	370	
Flat curves Rm=260 mm BICF ... - BICS ...	30° track = 360+360 45° track = 425+425 60° track = 495+495 90° track = 630+630 180° track = 1040+1040	
Vertical curves Rm=400 mm BICV ...	30° track = 365+420 45° track = 425+495 60° track = 550+655 90° track = 730+890	

Structure of standard BIFLEX conveyor

A single Biflex conveyor is made up of number of modular blocks that allows to create any type of layout. This catalogue contains the descriptions of all standard modules:

- Straight channels (from page 6)
- Motor drives (from page 12)
- Return ends (from page 29)
- Curves (from page 34)
- Lateral guides (from page 41)
- Ground supports (from page 63)

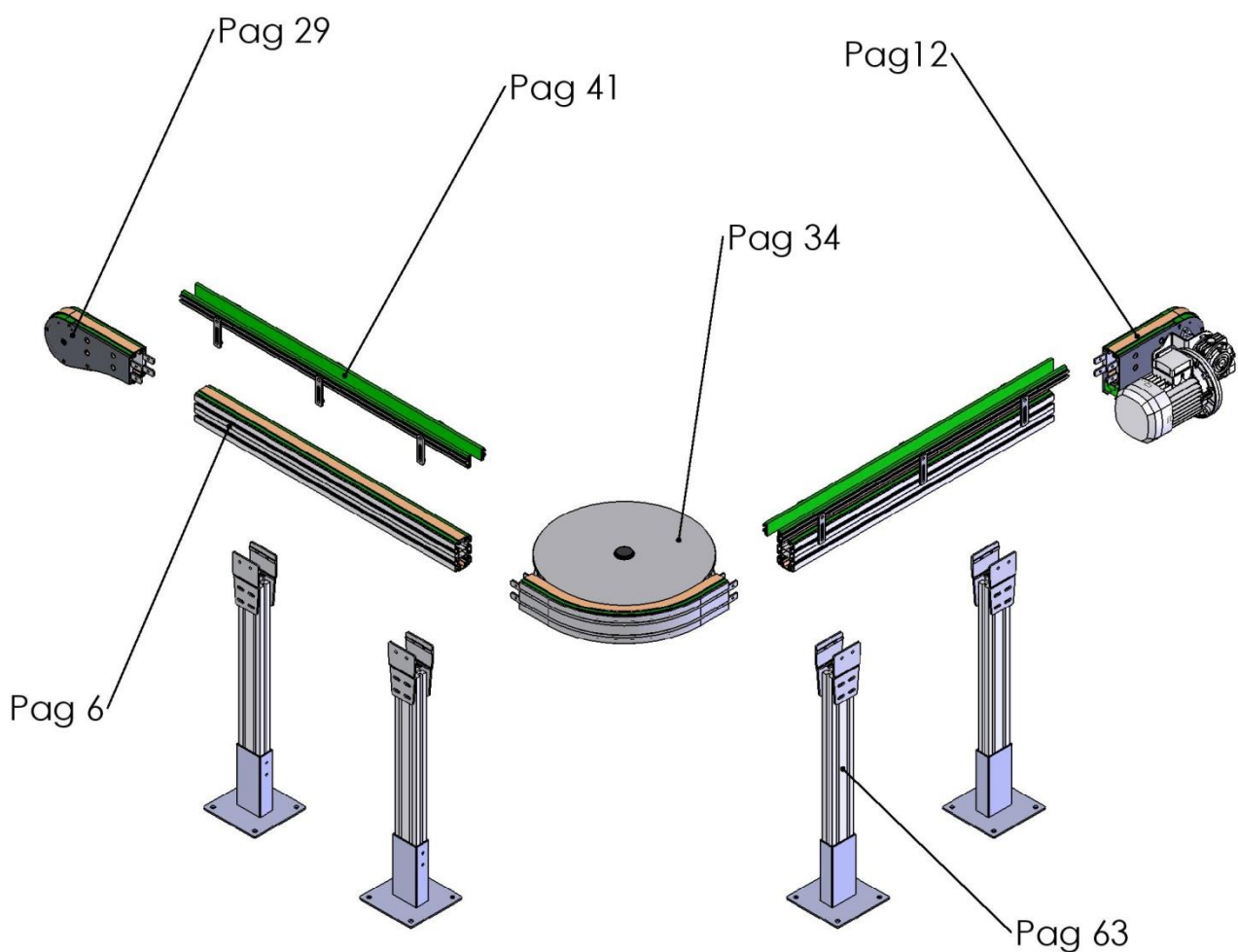
**NOTE:**

The drawings in this catalogues can be subject to graphical simplifications and therefore may not represent the actual final look of the product. If real drawings of components are necessary to assess space requirements, please contact our Technical Office for more information.



Fundamental characteristics of the chain guide channel

Standard Biflex chain guide channel has a configuration that allows to guide the chain in both forward and return paths.

The standard chain guide channel is made with an extruded profile of natural coloured anodized aluminum (12-15 Microns thick).

The chain slideways are made in polyethylene with high molecular weight.

Guides are mounted by snapping, using the particular shape of the extruded aluminum profile. Then the slideway profile must be fastened with countersunk M4 screws.

Channels can be connected together with 4 plates (2 for the SLIM version) with blocking screws inserted in the external cavities of the profile.

The side hollows of the profile were designed to allow mounting of a large number of supports for the product guides and accessories like photocells, channels for collecting debris, and other elements.

The particular geometry of the slot (patented) also allows the use of standard nuts and bolts found on the market.

The grooves can be closed for aesthetic or hygienic reasons with a plastic profile that can be snapped in place.

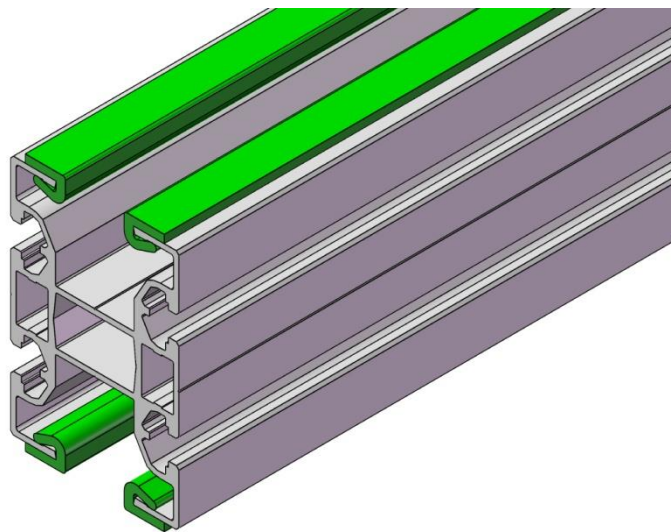



Biflex chain guide channel

Material : Anodized aluminum
Length : 6 m

Order Code: BI R 11104

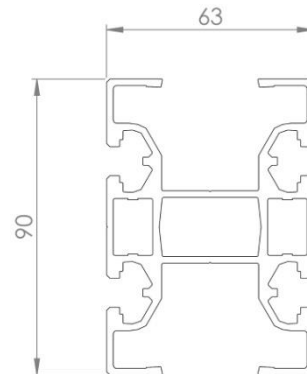

NOTE:

Channels are sold in bars of 6 meters. Custom cut pieces of channels can be ordered on request. In this case, the price will be calculated by estimating the length to the next half meter and applying a surcharge for each cut made (please consult the price list for details).

Aluminum chain channel slideway

Material : Polyethylene
Colour : Green
Packaging : 50 m

Order Code: GS1

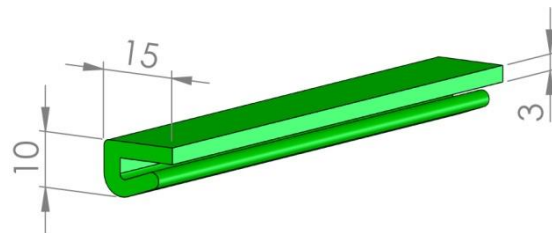

High performance chain slideway

Material : Nolu S
Colour : Grey
Packaging : 60 m

Order Code: GS1 NS

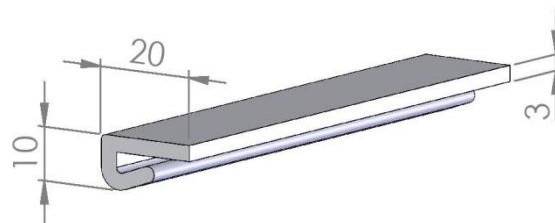

NOTE:

Slideways are normally sold in 50/60 meter rolls. Smaller quantities can be ordered on request. The price will be rounded to the next meter.

Channel joining plate

Material : Galvanized steel
 : Stainless steel
 Packaging : 50 pieces with bolts

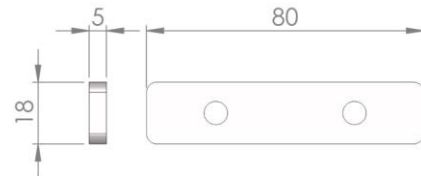

Order Code: PG1
Stainless Steel Version: PGX1

Biflex Joining plate

Material : Galvanized steel
 Packaging : 2 pieces with screws
 These joining plates are used to join channels with a maximum slant of 11°.

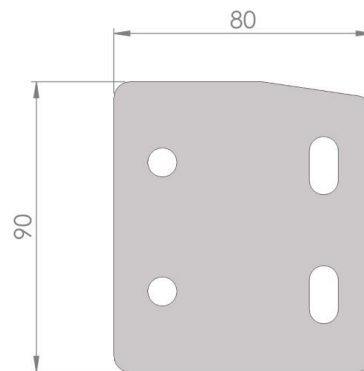

Order Code: PG4

Inspection zone

To facilitate the disassembly of the chain, it's possible to predispose a piece of channel divided in 2: in this way it allows an easy access to the chain junction.
 This group is called inspection zone and normally is positioned near to the return end, where the chain stress is minimum.
 Is enough to loosen the bolts and scroll the joining plates (only on one side of the inspection zone) to release one piece of lateral side and to access to the chain.

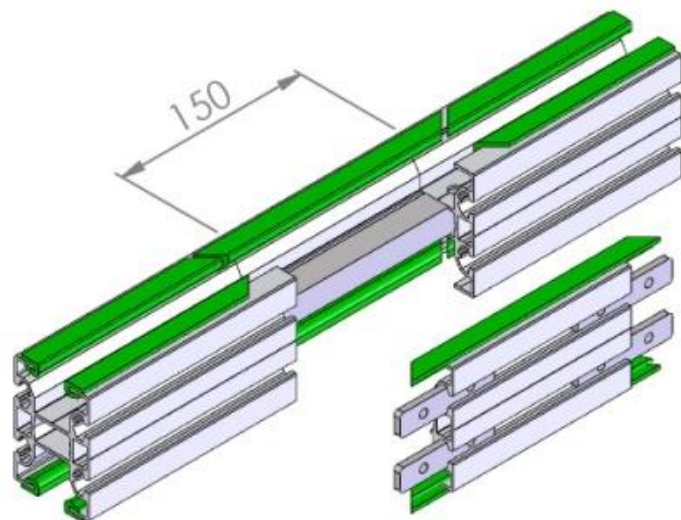

Channel section for disassembly, inspection and clearing of the chain and of the conveyor. Including joining plates and bolts.

Order Code: BI SI

Chains

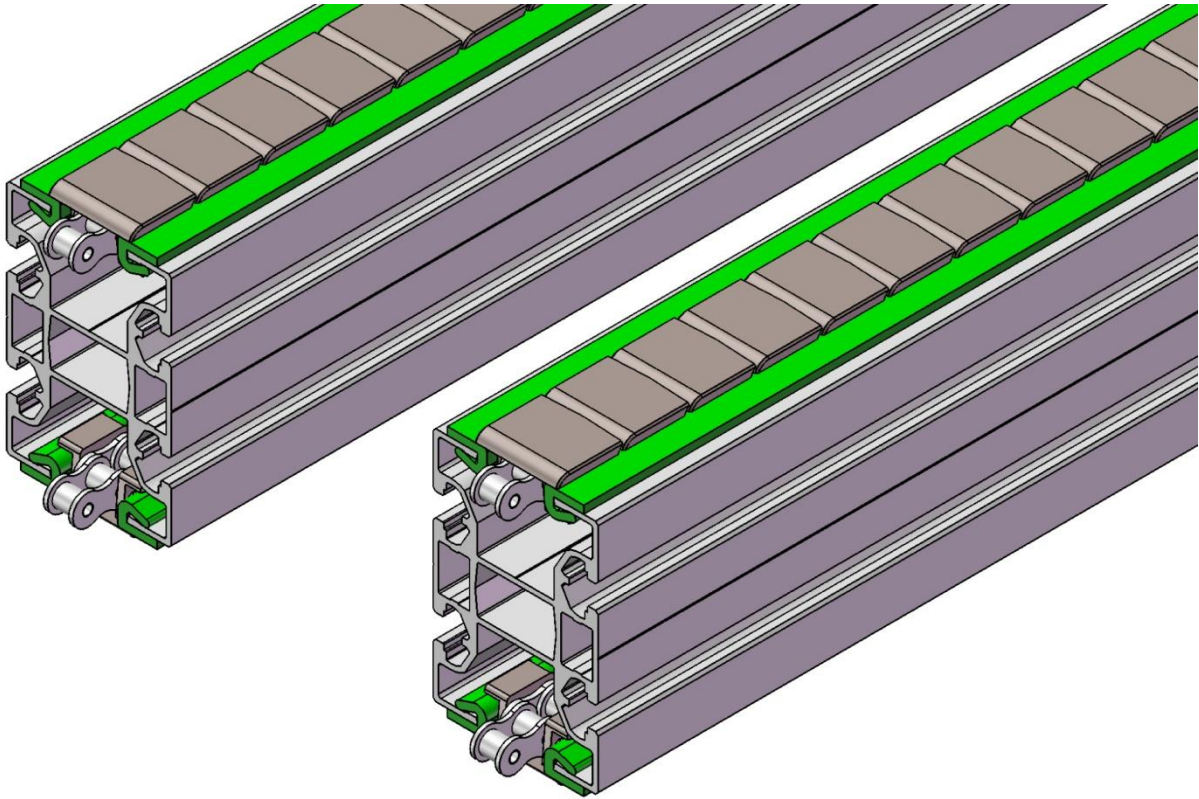

Typical Applications



PLASTIC AND
GLASS BOTTLES



DOYPACK TYPE SACKS



PACKAGED CHEESES



PHARMACEUTICAL FLACONS



TINS, CANS, AND JARS



MECHANICAL ELEMENTS
AND ELECTRICAL PARTS



BAGS FOR BISCUITS
AND BAKED PRODUCTS



PRODUCTS IN PLASTIC
BLISTER PACKS



PACKAGES FOR RICE, COFFEE
AND VACUUM-PACKED PRODUCTS



PRODUCTS ON PALLETES



Standard chain

The Biflex 1843 chain is made with table-top pieces in acetalic resin and teflon snapped together onto a chain of steel rollers: its configuration allows a heavier load and faster speed than the chains with acetalic resin links joined by steel pins.

Also, the interlocking movement with sprockets is quieter and allow more precise positioning, due to less play between the chain and the sprocket teeth.

The standard chain can be built also in Polycarbonate or WRB resin (wear resistant).

On request, stainless steel rollers are also available.

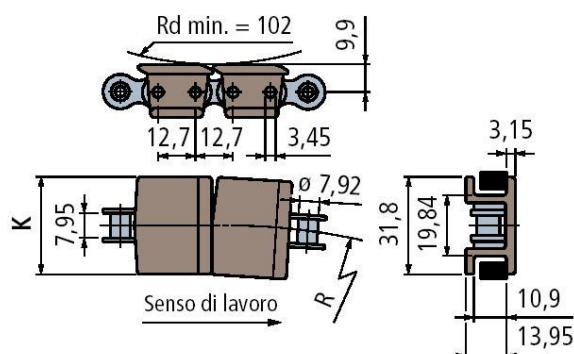

Design

Colour : Brown

Specifications

	K125	K200
Width K (mm)	31,8	50,6
Weight (Kg/m)	0,83	0,9
Average curve radius (mm)	260	260

Materials

Table top piece : Acetalic resin and Teflon

Chain rollers : Steel

Supply length

3.05 meters per package

Optional materials

Polycarbonate

WRB Resin (Wear resistant)

Order Code: BI LF 1843 K 125
BI LF 1843 K 200

Chain in resin with flexible flights

The Biflex LF 1843 K150 GJ chain is made with table-top pieces in acetalic resin and teflon snapped together onto a chain of steel rollers. An elastic rubber flight is injection moulded into the chain that allows vertical transport on elevators-lowerators.

The rubber of the flights has a standard hardness of 90 Shore A. On request, a hardness of 60 Shore A is available.

A version with a square flight, GD model, is also available: the characteristics are the same, but this model is more suitable for the realization of vertical elevators with opposed chains for boxes of medium/high load.

As for the standard chain, the configuration of Biflex LF 1843 K150 GJ allows a heavier load and faster speed than the chains with acetalic resin links joined by steel pins.

Also, the interlocking movement with sprockets is quieter and allow more precise positioning, due to less play between the chain and the sprocket teeth.

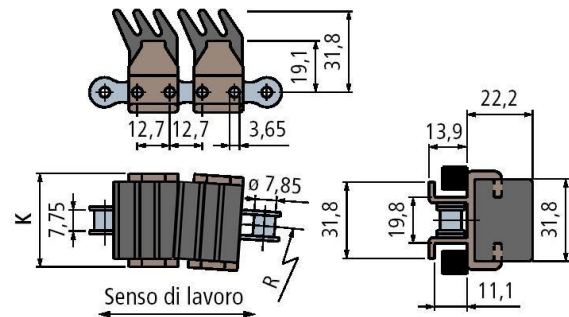

Design

Colour : Brown
Flight colour : Dark grey

Specifications

Width K : 38,1 mm
Weight : 1,2 Kg/m
Average curve radius (mm) : 260 mm

Materials

Chain : Acetalic resin and Teflon
Flights : Elastic rubber
Pin : Steel

Supply length

3.05 meters per package

Flight hardness options

60 Shore A

Order Code: BI LF 1843 K 150 GJ
BI LF 1843 K 150 GD



End motor drive

The end drive is the most used to make conveyors of any shape with forward and backward paths. The most natural configuration for a conveyor belt is with the motor drive "pulling" the chain.

Suspended end motor drive

The unit is mounted on the side of the motor and is directly connected to the chain drive sprocket.

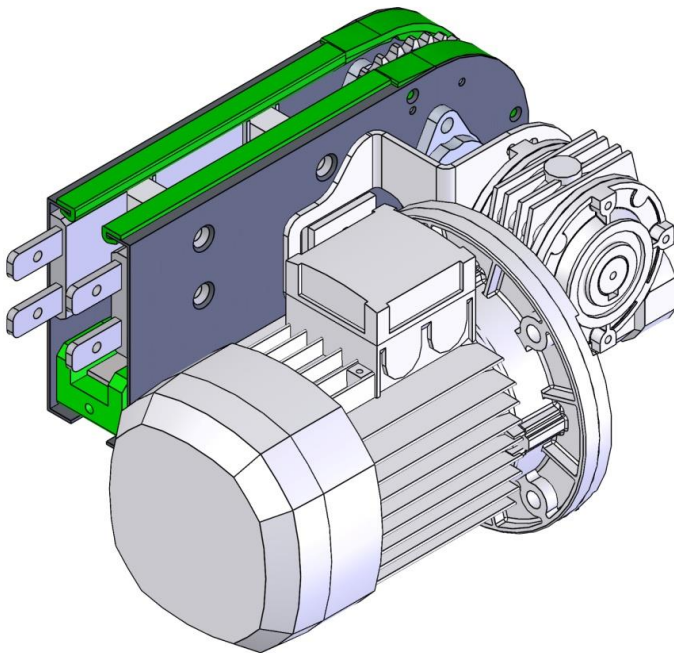

Technical specifications:

Standard motor	: Triphase 220/380 V
N° teeth drive sprocket	: Z 25 Dp. 153 mm
Standard speed at 50 Hz (m/min)	: 6.5, 14, 23, 35.5, 64

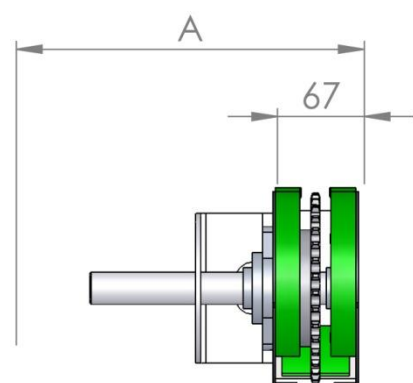
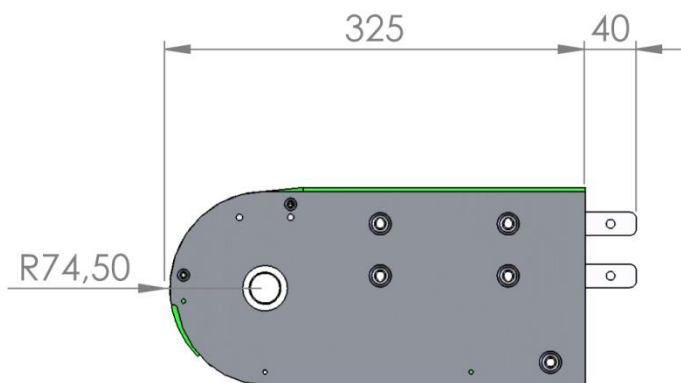

A = Volume depending to the motor gear type

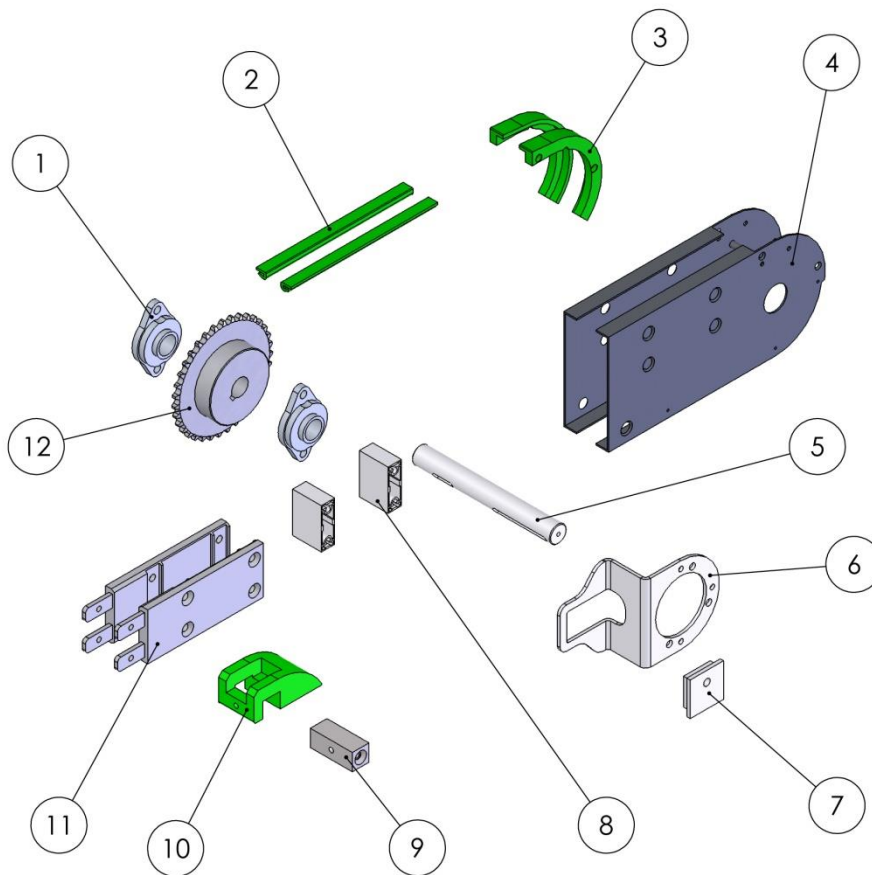

Article Number	Description	Article Code
1	SUPPORT IN ALLOY DIAMETER 25	UFL005
2	CHAIN SLIDEWAY	GS1
3	RIGHT/LEFT UNDERCHAIN SLIDE	F5TM35D F5TM35S
4	RIGHT/LEFT END MOTOR DRIVE PLATE	F5TM26 F5TM27
5	REACTION LEVER	*
6	REACTION ARM PIN	F5TM06
7	DRIVE SHAFT	*
8	INTERNAL SPACER	BITR03
9	RETURN END SLIDE SUPPORT SPACER	BIMP09
10	POLYETHYLENE SLIDE	14343
11	END MOTOR DRIVE PLATE IN CAST ALUMINIUM	F5PG14
12	DRIVE WHEEL	

* Depends on the motor type

The parts indicated are not sold separately unless they are present in this catalogue in the designated section.

Suspended end motor drive with guided chain

The unit is mounted on the side of the motor and is directly connected to the chain drive sprocket. This type of head can be used for applications with transporters of limited lengths or that run at high speeds. If combined with a tensioned return head (contact the technical office for this special execution) it can "push" the conveyor.

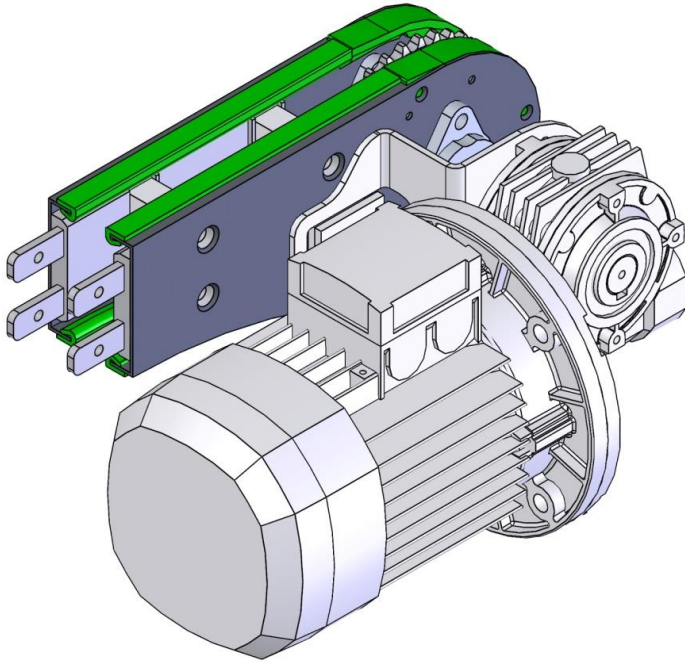

Technical specifications:

Standard motor	: Triphase 220/380 V
N° teeth drive sprocket	: Z 25 Dp. 153 mm
Standard speed at 50 Hz (m/min)	: 6.5, 14, 23, 35.5, 64

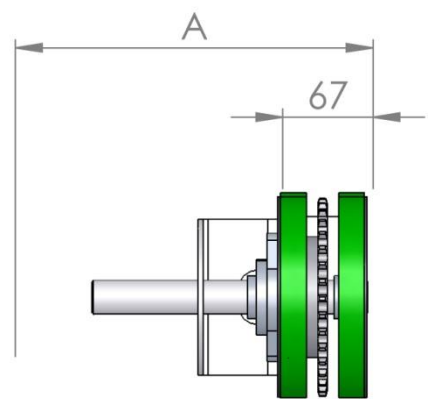
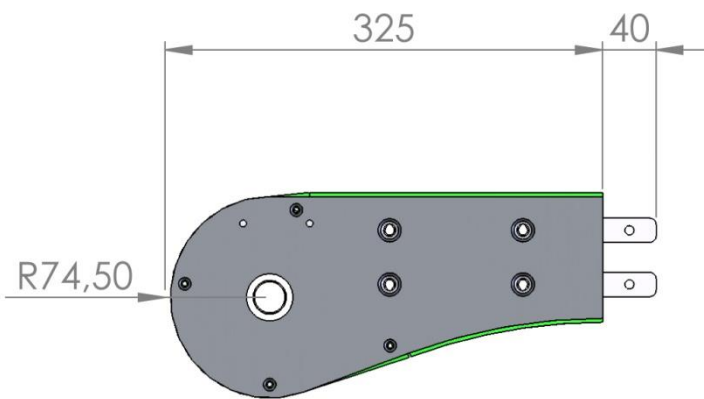

A = Volume depending to the motor gear type

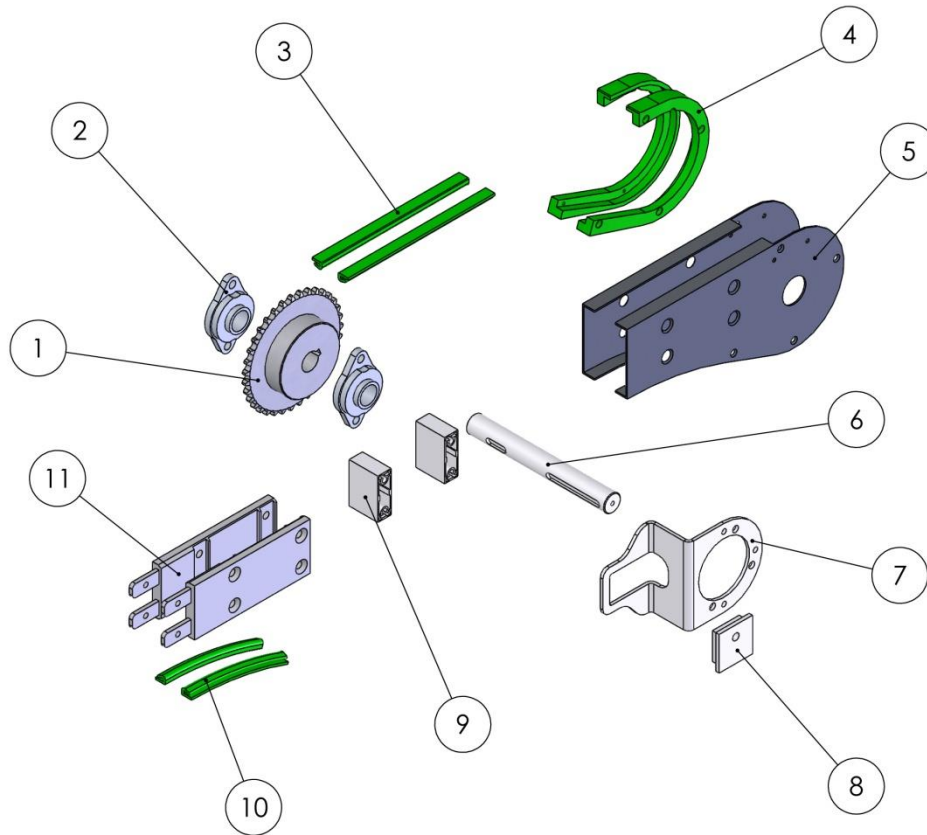

Article Number	Description	Article Code
1	DRIVE WHEEL	
2	SUPPORTO IN ALLOY DIAMETER 25	UFL005
3	CHAIN SLIDEWAY	GS1
4	RIGHT/LEFT UNDERCHAIN SLIDE	F5TR13D F5TR13S
5	RIGHT/LEFT PLATE FOR 180° RETURN MOTOR DRIVE PLATE WITH HOLE DIAM 35 mm.	F5TRMD F5TRMS
6	DRIVE SHAFT	*
7	REACTION LEVER	*
8	REACTION ARM PIN	F5TM06
9	INTERNAL SPACER	BITR03
10	CHAIN SLIDEWAY	GS1
11	CAST ALUMINIUM END MOTOR DRIVE PLATE	F5PG14

* Depends on the motor type

The parts indicated are not sold separately unless they are present in this catalogue in the designated section.

Transferred end motor drive

The transferred drive kit allows to move the position of the gear motor with respect to the axis of the drive sprocket. These are commonly used when it is necessary to reduce the space occupied by the end motor drive unit.

Transmission chain tension is regulated by using the available space in the slots on the support plate of the motor unit. The transmission has a suitable safety protection which must always be in its place when the conveyor is moving.

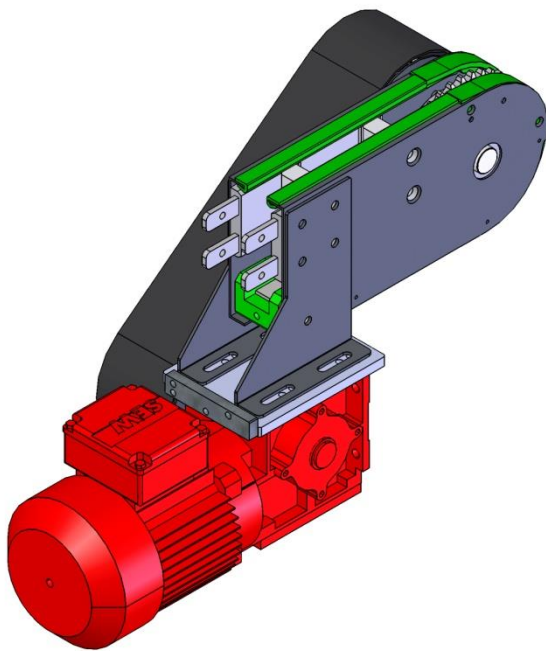

Technical specifications:

Standard motor : Triphase 220/380 V

N° teeth drive sprocket : Z 25 Dp. 153 mm

Standard speed at 50 Hz (m/min) : 6.5, 14, 23, 35.5, 64

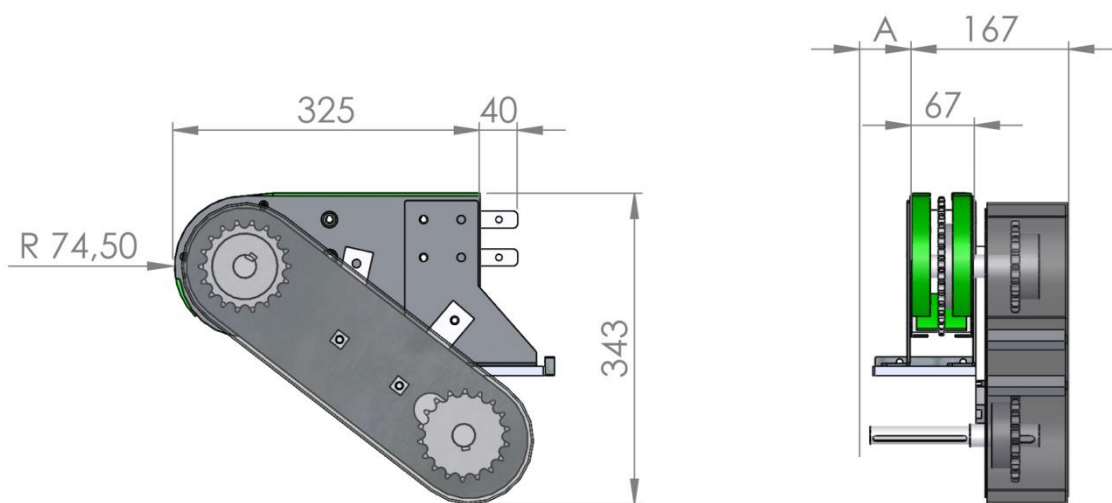

Volume depending to the motor gear type = A+167 mm

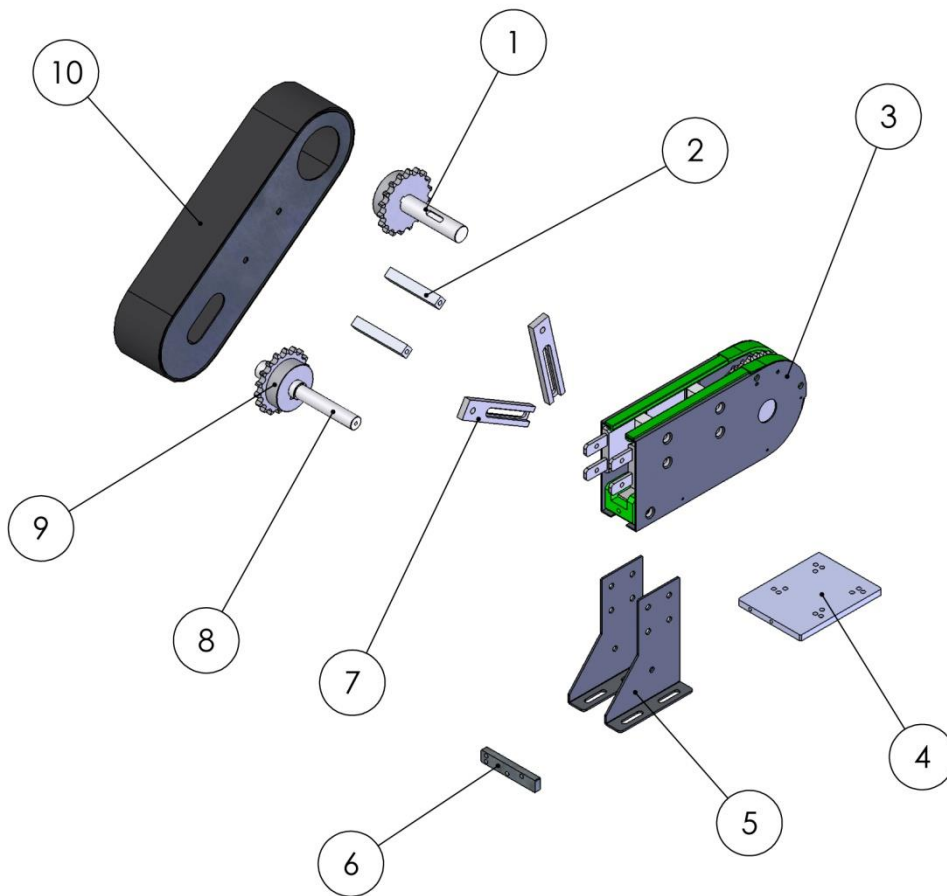

Article Number	Description	Article Code
1	MOTORISED SHAFT IN AISI 304	BIMRS-08
2	SAFETY PROTECTION SPACER	F5TM13
3	CLASSIC END MOTOR DRIVE	BIM
4	JOINING PLATE	*
5	REDUCTION GEAR BRACKET	F5TM09
6	TENSIONING BLOCK	BIMRS-02
7	SAFETY PROTECTION BRACKET	F5TM12
8	DRIVE SHAFT	*
9	SIMPLE SPROCKET	*
10	SAFETY PROTECTION	

* Depends on the motor type

The parts indicated are not sold separately unless they are present in this catalogue in the designated section.

Transferred end drive with guided chain

The transferred drive kit allows to move the position of the gear motor with respect to the axis of the drive sprocket. These are commonly used when it is necessary to reduce the space occupied by the end motor drive unit.

Transmission chain tension is regulated by using the available space in the slots on the support plate of the motor unit. The transmission has a suitable safety protection which must always be in its place when the conveyor is moving.

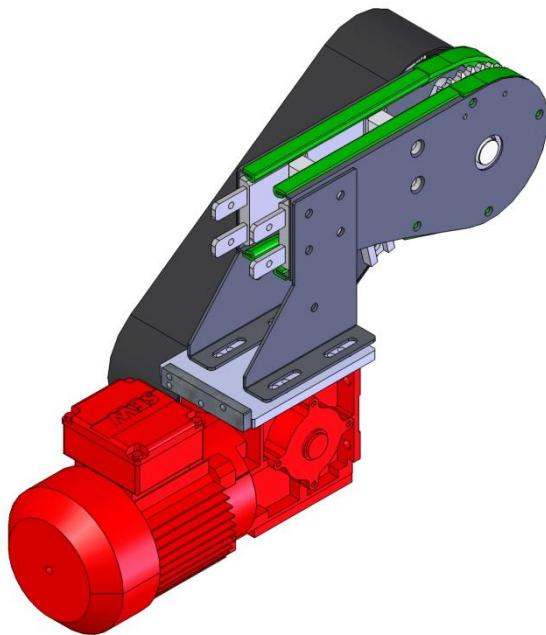

Technical specifications:

Standard motor : Triphase 220/380 V

N° teeth drive sprocket : Z 25 Dp. 153 mm

Standard speed at 50 Hz (m/min) : 6.5, 14, 23, 35.5, 64

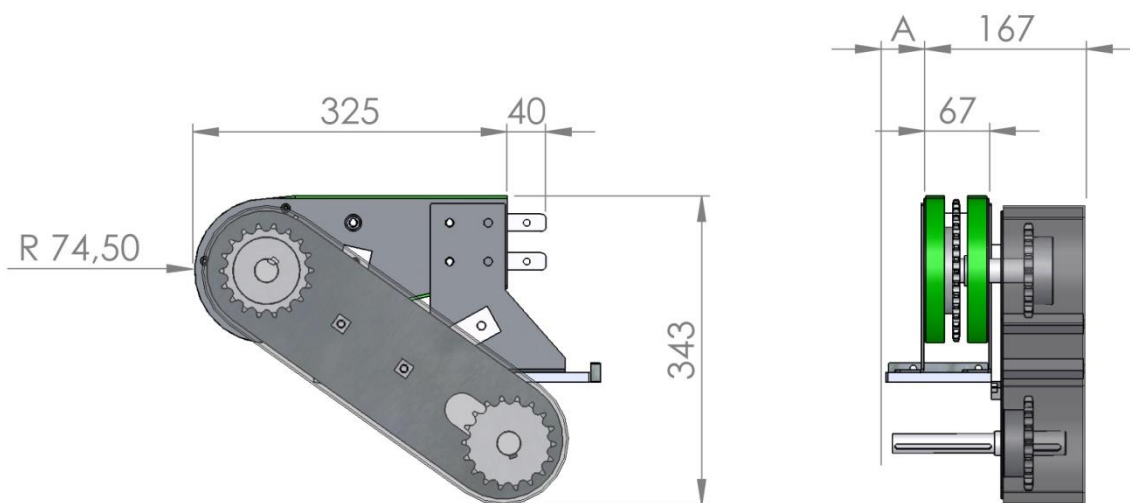

Volume depending to the motor gear type = A+167 mm

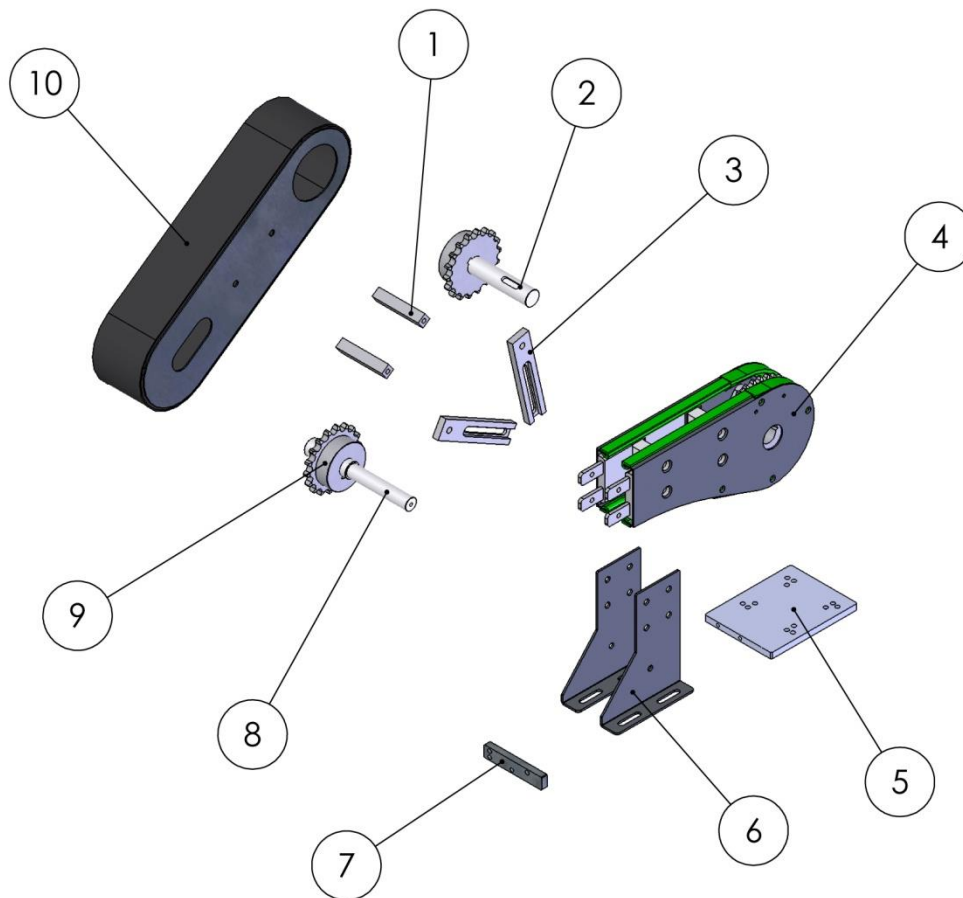

Article Number	Description	Article Code
1	SAFETY PROTECTION SPACER	F5TM13
2	MOTORISED SHAFT IN AISI 304	BIMRS-08
3	SAFETY PROTECTION BRACKET	F5TM12
4	END MOTOR DRIVE WITH GUIDED CHAIN	BIMCG
5	JOINING PLATE	*
6	REDUCTION GEAR BRACKET	F5TM09
7	TENSIONING BLOCK	BIMRS-02
8	DRIVE SHAFT	*
9	SIMPLE SPROCKET	*
10	SAFETY PROTECTION	

* Depends on the motor type

The parts indicated are not sold separately unless they are present in this catalogue in the designated section.

Central motor drive

The central motor drive can be installed at any point along the conveyor. It is normally used when the conveyor has a closed ring configuration. The best working conditions are obtained by positioning the drive as closely as possible to the point in where the greatest load is situated. Central drive considers also a roller passage to facilitate the transport continuity.

Suspended motor drive

The unit is mounted on the side of the motor and is directly connected to the chain drive sprocket.

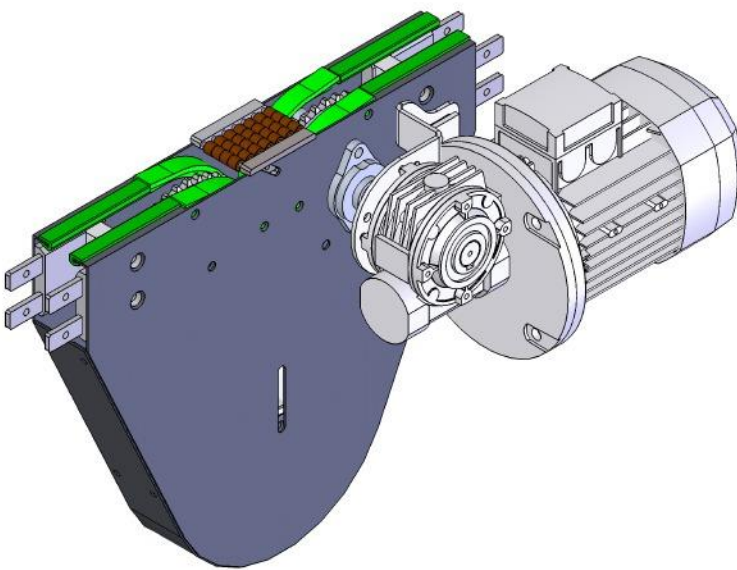

Technical specifications:

Standard motor : Triphase 220/380 V

N° teeth drive sprocket : Z 25 Dp. 153 mm

Standard speed at 50 Hz (m/min) : 6.5, 14, 23, 35.5, 64

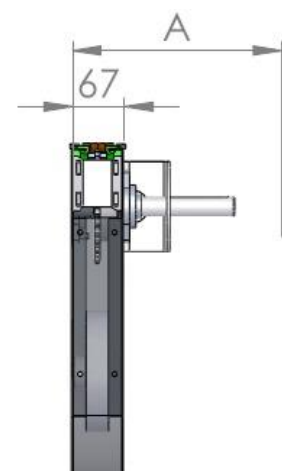
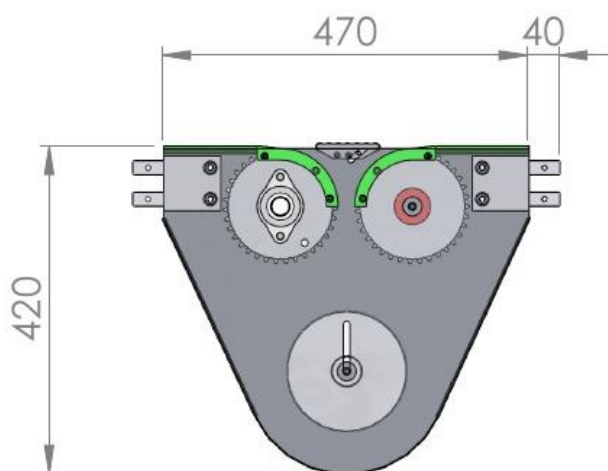

A = Volume depending to the motor gear type

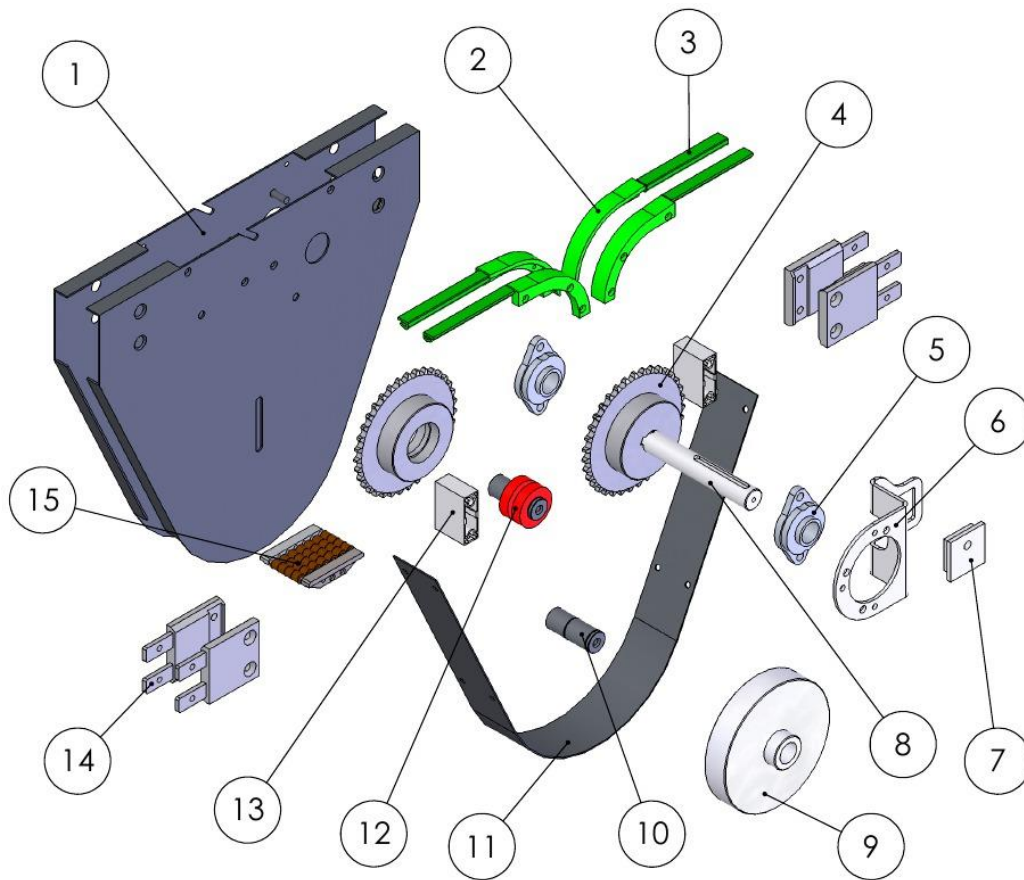

Article Number	Description	Article Code
1	LEFT/RIGHT PLATE FOR CENTRAL MOTOR DRIVE	F5MC01D F5MC01S
2	LEFT/RIGHT UNDERCHAIN SLIDE	F5TM35D F5TM35S
3	CHAIN SLIDEWAY	GS1
4	DRIVE WHEEL	
5	SUPPORT IN ALLOY DIAMETER 25	UFL005
6	REACTION LEVER	*
7	REACTION ARM PIN	F5TM06
8	DRIVE SHAFT	*
9	RETURN WHEEL IN BLACK GLISTAMIDE	BIRMC
10	180° RETURN END SHAFT IN STAINLESS STEEL AISI 304	BITR05
11	UPPER SAFETY PROTECTION	BIMC02
12	BEARINGS	6004-2RS
13	INTERNAL SPACER	BITR03
14	CAST ALUMINIUM MOTOR DRIVE PLATE	F5PG13
15	ROLLER PASSAGE	BIPARUL

* Depends on the motor type

The parts indicated are not sold separately unless they are present in this catalogue in the designated section.

Transferred motor drive

The transferred drive kit allows to move the position of the gear motor with respect to the axis of the drive sprocket. These are commonly used when it is necessary to reduce the space occupied by the end motor drive unit.

Transmission chain tension is regulated by using the available space in the slots on the support plate of the motor unit. The transmission has a suitable safety protection which must always be in its place when the conveyor is moving.

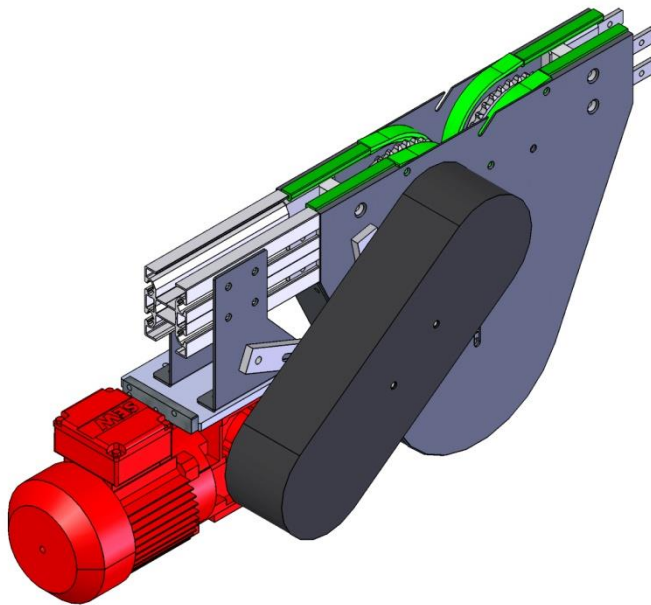

Technical specifications:

Standard motor	: Triphase 220/380 V
N° teeth drive sprocket	: Z 25 Dp. 153 mm
Standard speed at 50 Hz (m/min)	: 6.5, 14, 23, 35.5, 64

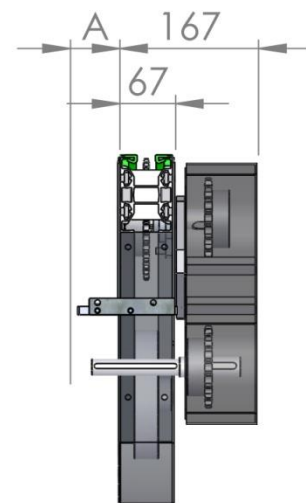
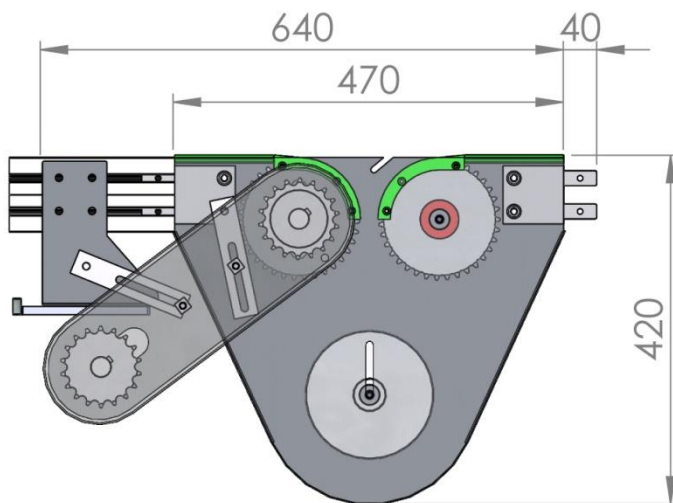

Volume depending to the motor gear type = $A+167$ mm

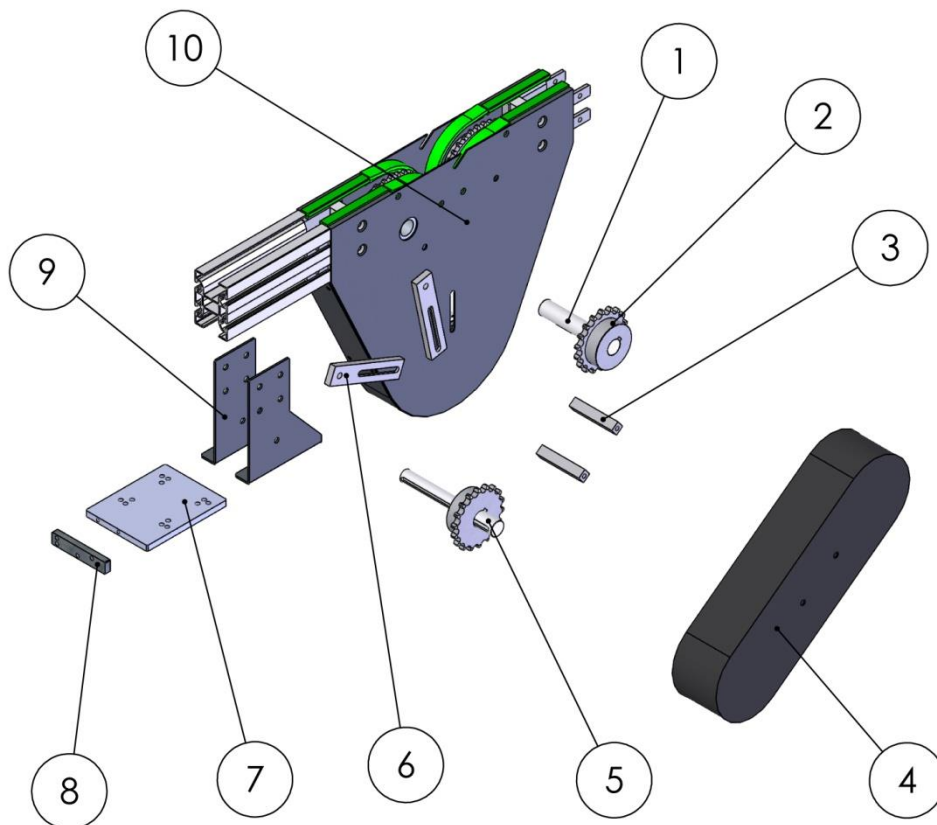

Article Number	Description	Article Code
1	MOTORISED SHAFT IN AISI 304	BIMRS-08
2	SIMPLE SPROCKET	*
3	SAFETY PROTECTION SPACER	F5TM13
4	SAFETY PROTECTION	
5	DRIVE SHAFT	*
6	SAFETY PROTECTION BRACKET	F5TM12
7	JOINING PLATE	*
8	TENSIONING BLOCK	BIMRS-02
9	REDUCTION GEAR BRACKET	F5TM09
10	CENTRAL MOTOR DRIVE	BIMC

* Depends on the motor type

The parts indicated are not sold separately unless they are present in this catalogue in the designated section.



Intermediate motor drive on chain return

The intermediate motor drive on the chain return can be installed at any point along the conveyor. It is used when at the ends of the conveyor there is insufficient space to place the drive unit. The best work conditions are obtained by positioning the drive unit as closely as possible to the return drive, placed and the end of the conveyor with respect to the direction of the belt. The drive sprocket operates on the return section of the chain.

Suspended motor drive

The unit is mounted on the side of the motor and is directly connected to the chain drive sprocket.

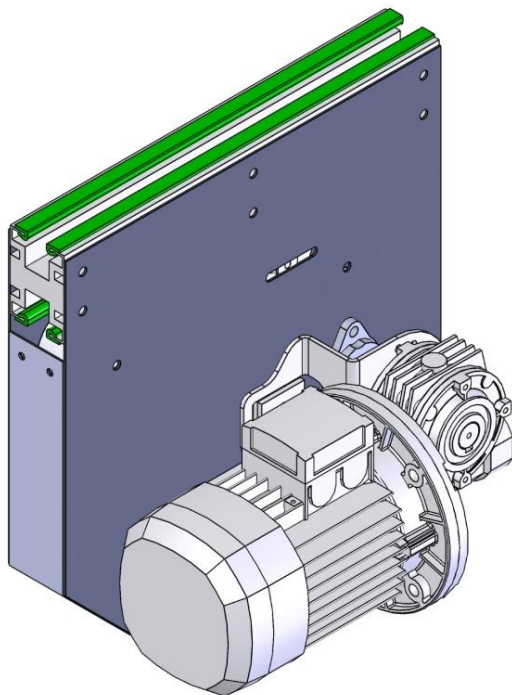

Technical specifications:

Standard motor	: Triphase 220/380 V
N° teeth drive sprocket	: Z 25 Dp. 153 mm
Standard speed at 50 Hz (m/min)	: 6.5, 14, 23, 35.5, 64

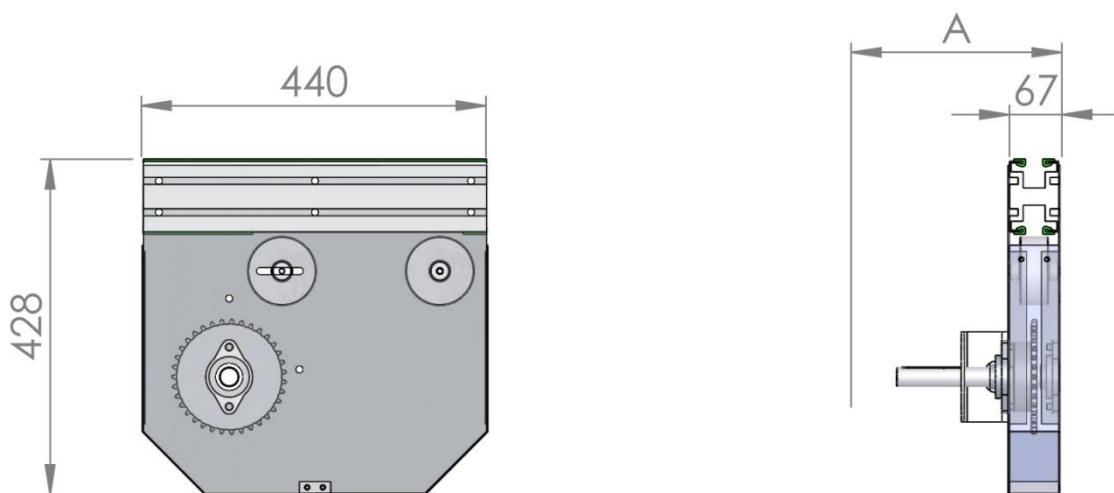

A = Volume depending to the motor gear type

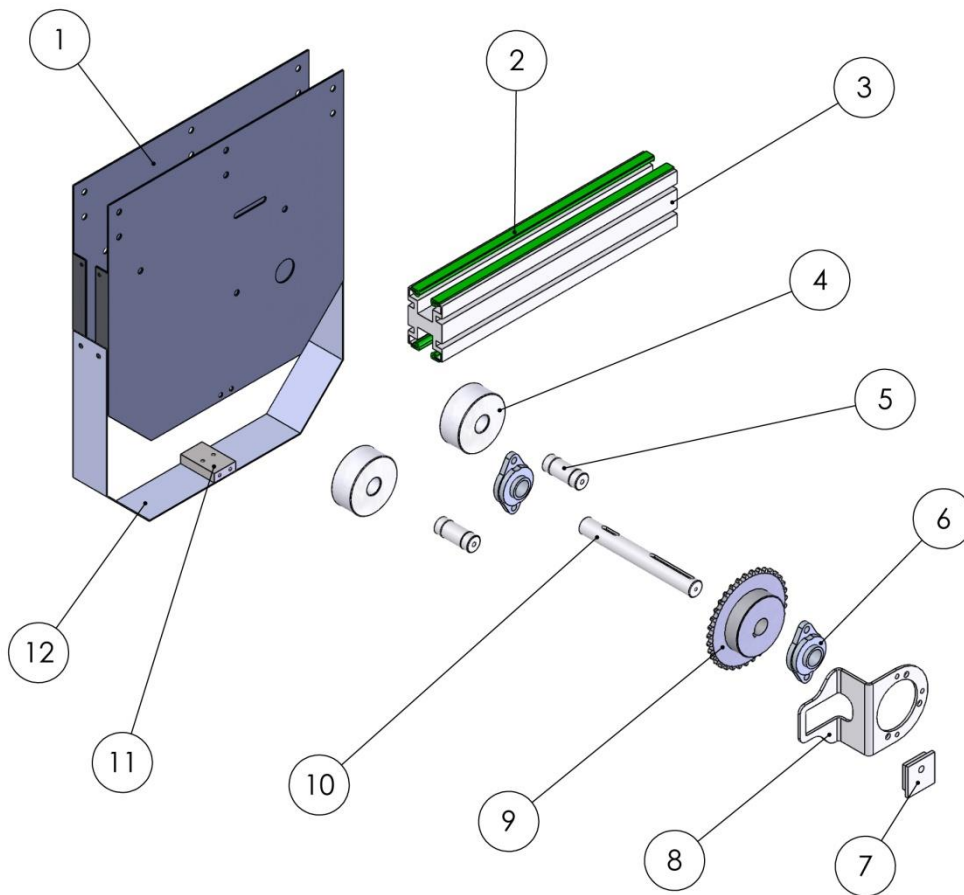

Article Number	Description	Article Code
1	RIGHT/LEFT PLATE	F5TC05 F5TC06
2	CHAIN SLIDEWAY	GS1
3	CHANNEL	F5R5039
4	IDLE ROLLER	MFPR09
5	180° RETURN END SHAFT IN STAINLESS STEEL AISI 304	BITM11
6	SUPPORT IN ALLOY DIAMETER 25	UFL005
7	REACTION ARM PIN	F5TM06
8	REACTION LEVER	*
9	DRIVE WHEEL	
10	DRIVE SHAFT	*
11	SAFETY PROTECTION SPACER	BIMP10
12	SAFETY PROTECTION	BIMC04

* Depends on the motor type

The parts indicated are not sold separately unless they are present in this catalogue in the designated section.



Transferred motor drive

The transferred drive kit allows to move the position of the gear motor with respect to the axis of the drive sprocket. These are commonly used when it is necessary to reduce the space occupied by the drive unit.

Transmission chain tension is regulated by using the available space in the slots on the support plate of the motor unit. The transmission has a suitable safety protection and is always in its place when the conveyor is moving.

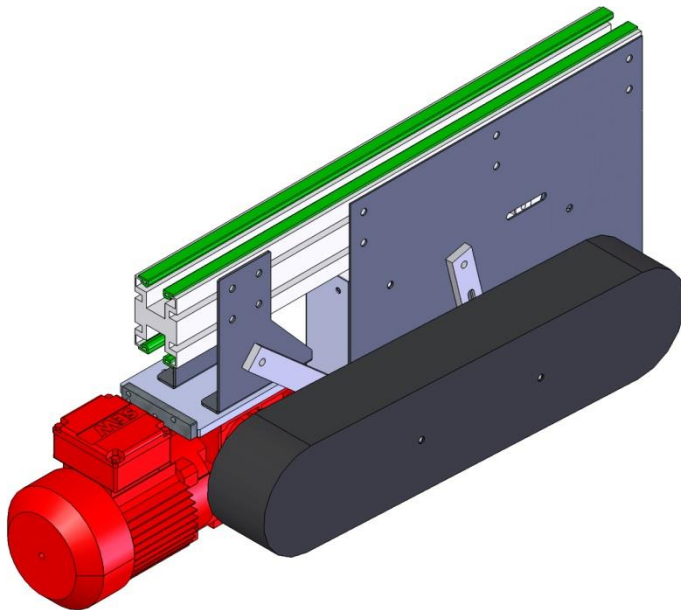

Technical specifications:

Standard motor	: Triphase 220/380 V
N° teeth drive sprocket	: Z 25 Dp. 153 mm
Standard speed at 50 Hz (m/min)	: 6.5, 14, 23, 35.5, 64

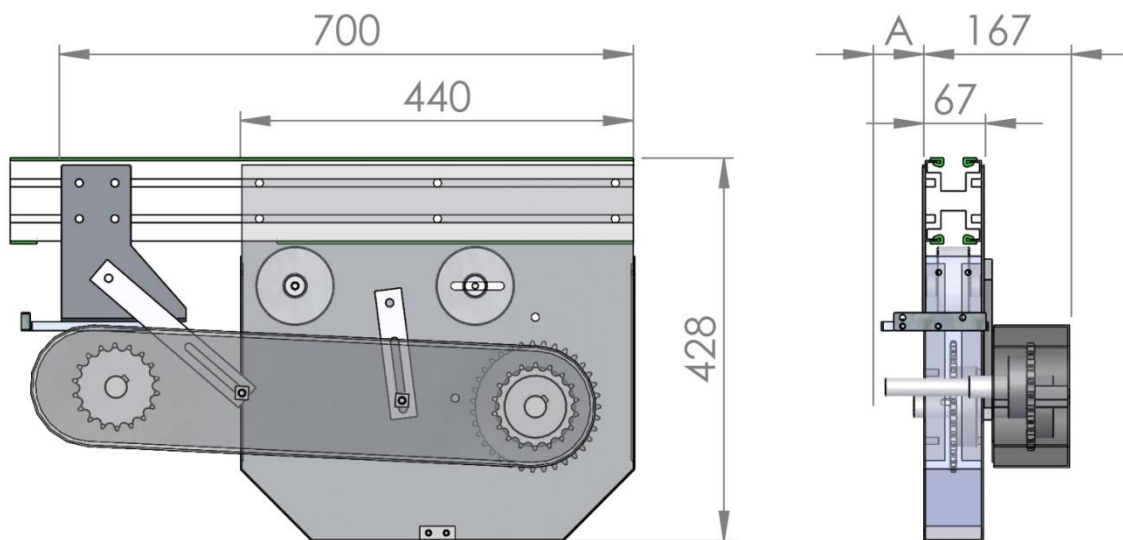

Volume depending to the motor gear type = A+167 mm

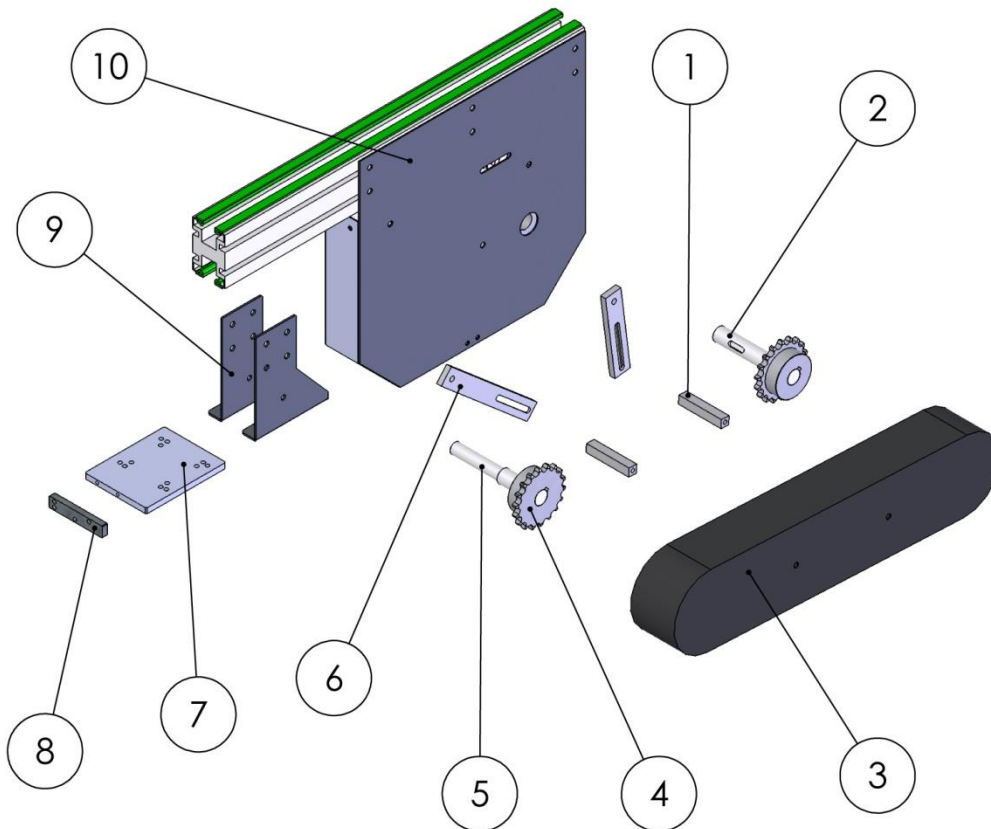

Article Number	Description	Article Code
1	SAFETY PROTECTION SPACER	F5TM13
2	MOTORISED SHAFT IN AISI 304	BIMRS-08
3	SAFETY PROTECTION	
4	SIMPLE SPROCKET	*
5	DRIVE SHAFT	*
6	SAFETY PROTECTION BRACKET	F5TM12
7	JOINING PLATE	*
8	TENSIONING BLOCK	BIMRS-02
9	REDUCTION GEAR BRACKET	F5TM09
10	INTERMEDIATE MOTOR DRIVE	BIMI

* Depends on the motor type

The parts indicated are not sold separately unless they are present in this catalogue in the designated section.

HOW TO WRITE THE ORDER CODES FOR MOTOR DRIVES

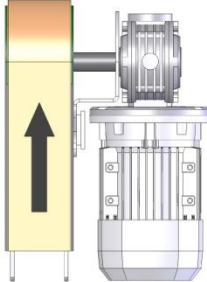
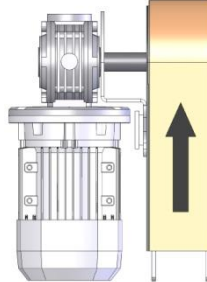
Description	Order Code	
Motor drive type	Suspended end : BIMP Transferred end : BIMR Suspended end with guided chain : BIMPCG Transferred end with guided chain : BIMRCG Central suspended : BIMCP Central transferred : BIMCR Intermediate suspended : BIMIP Intermediate transferred : BIMIR	
Drive side	Right: D 	Left: S 
Motor gear type	Bonfiglioli MVF49 Bonfiglioli W63 SEW WA20 SEW WA30	
Motor gear presence	Yes: Y No: N	

If purchasing the drive unit with your order, please specify the required speed at the time of ordering.

Example:

Right suspended end motor drive with SEW WA30 motor gear included

Cod: BIMP-D-WA30-Y

NOTE: For speeds above 20 m/min or in the presence of frequent starts or high loads, it is essential to put the motors under soft starter or inverter

Standard Returns

There are different standard return units to choose from depending on the construction requirements of the conveyor, for speeds of up to 70m/min. Every return unit has a chain guide around the entire track, to prevent the lower part from derailing.

180° Long final return

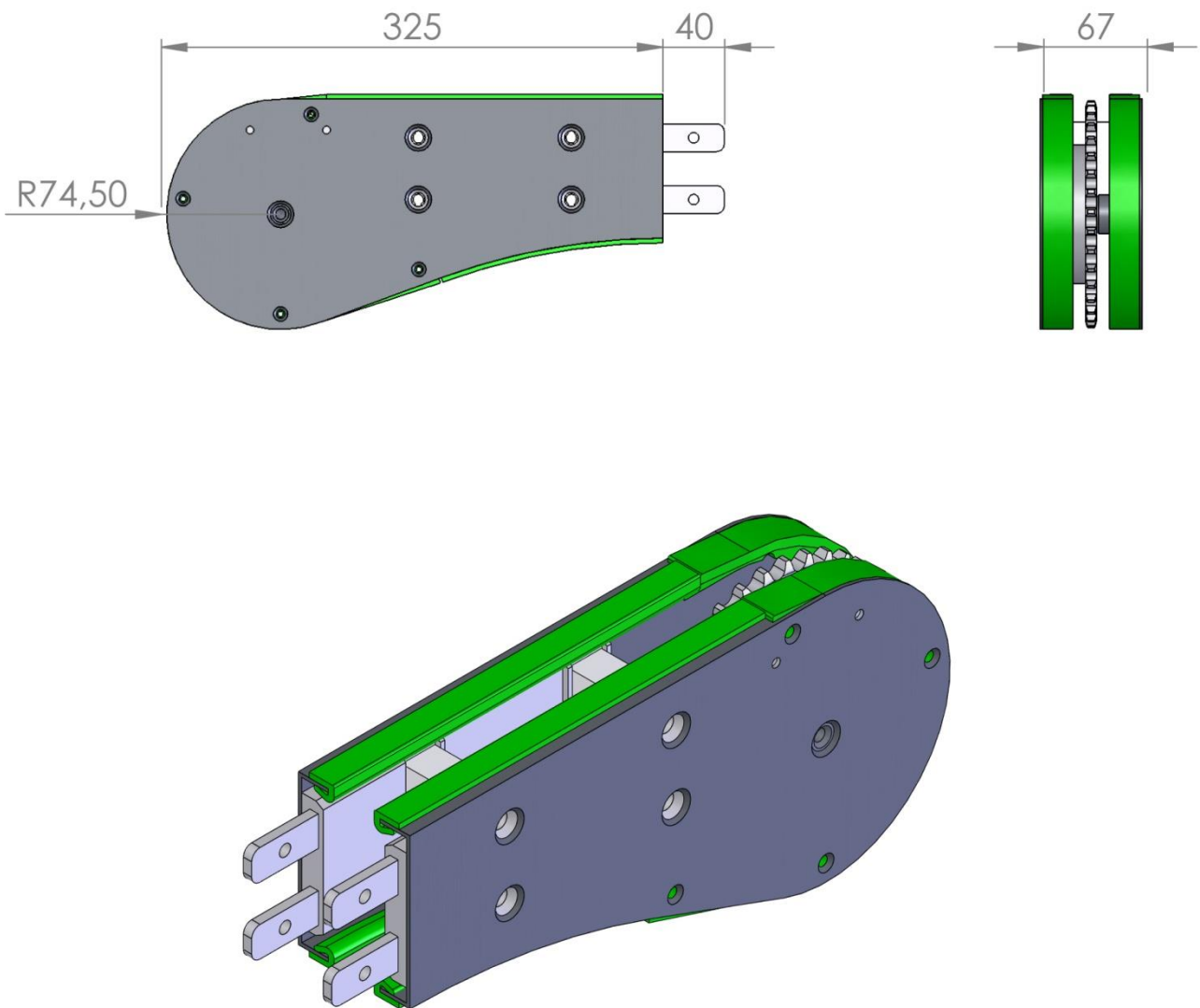

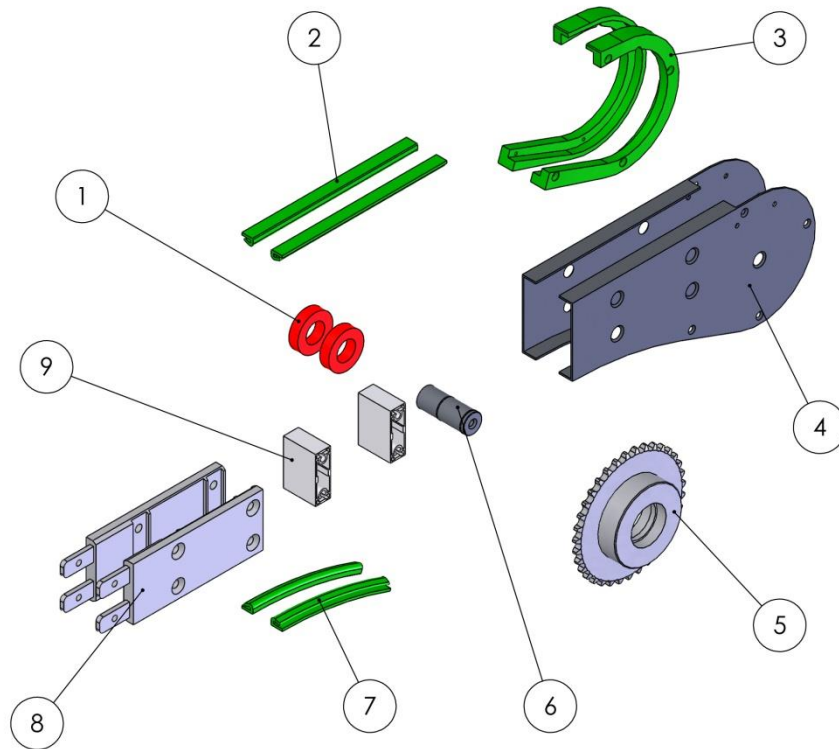

Article Number	Description	Article Code
1	BEARINGS	6002-2RS
2	CHAIN SLIDWAY	GS1
3	LEFT/RIGHT UNDERCHAIN SLIDE	F5TR13D F5TR13S
4	LEFT/RIGHT PLATE FOR 180° RETURN END WITH HOLE DIAM 35 mm	F5TRMD F5TRMS
5	RETURN WHEEL	F5RRRA
6	MOTOR DRIVE SHAFT FOR 180° RETURN IN AISI 304	BITR05
7	CHAIN SLIDWAY	GS1
8	CAST ALUMINUM MOTOR DRIVE	F5PG14D
9	INTERNAL SPACER	BITR03

The parts indicated are not sold separately unless they are present in this catalogue in the designated section.

Order Code: BIRL

180° Short final return

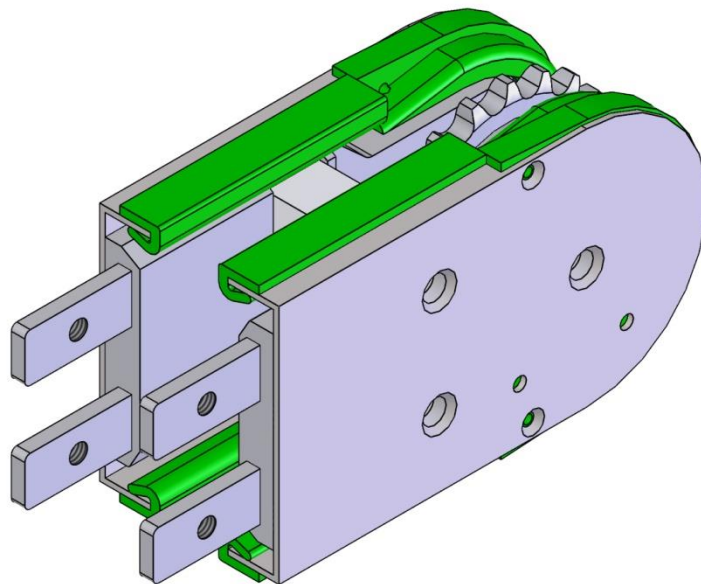
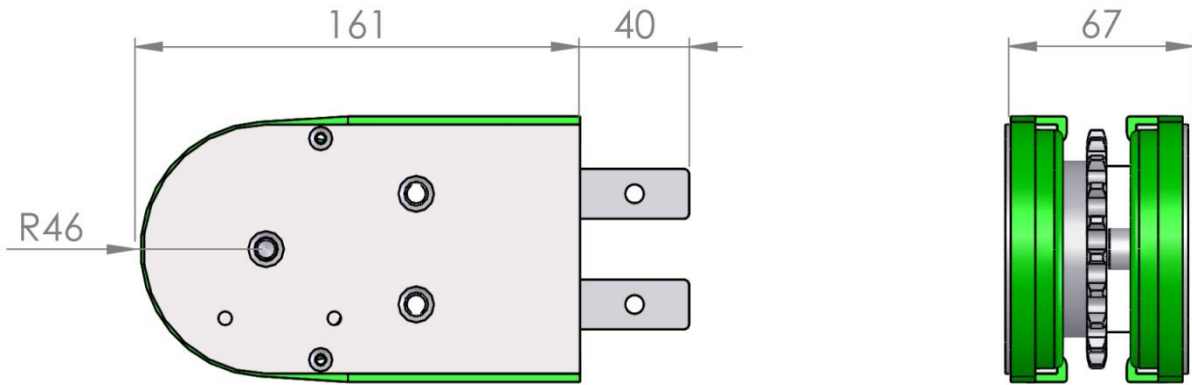

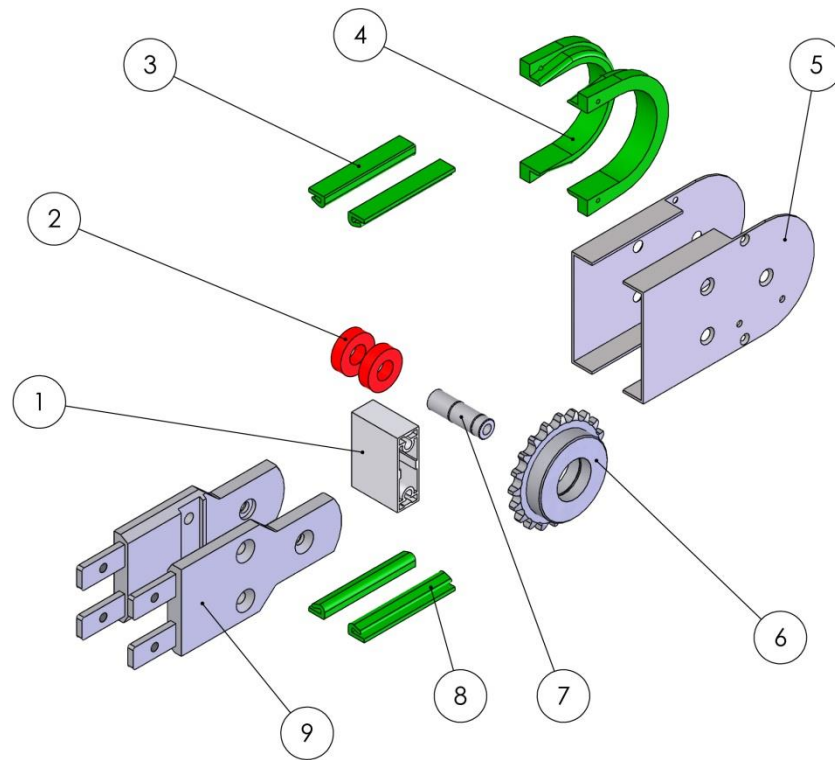

Article Number	Description	Article Code
1	INTERNAL SPACER	BITR03
2	BEARINGS	6002-2RS
3	CHAIN SLIDEWAY	GS1
4	UNDERCHAIN SLIDE	F5TR11
5	PLATE FOR 180° SHORT RETURN END SHAFT IN STAINLESS STEEL AISI	F5TR32D F5TR32S
6	RETURN SPROKET	
7	SHAFT FOR 180° SHORT RETURN END IN STAINLESS STEEL AISI 304	BITR01
8	LEFT/RIGHT PLATE FOR SHORT RETURN END	GS1
9	LEFT/RIGHT PLATE FOR 180° SHORT RETURN END IN CAST ALUMINUM	F5PG13

The parts indicated are not sold separately unless they are present in this catalogue in the designated section.

Order Code: BIRC

Safety protection devices on the end drives

End motor drives safety protection

Cod.: BI-MPT

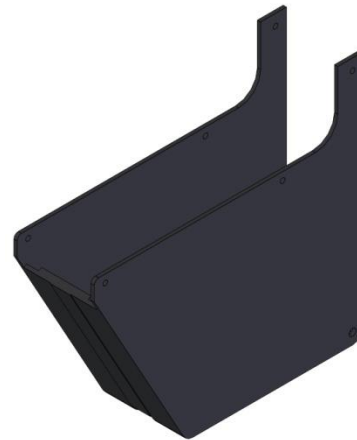

End motor drives safety protection

Cod.: BI-PRL

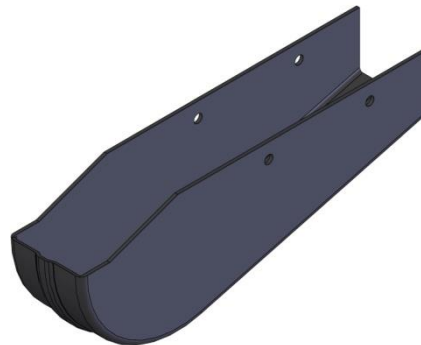

End motor drives safety protection

Cod.: BI-TR04

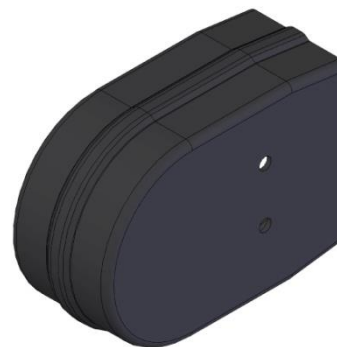

Curves

Flat curves with idle disk

Flat curves with idle disk are used to allow the conveyor to change directions. They reduce the friction during function as much as possible.

The curve and idle disk are made to constantly guide the chain. The disk is supported by two waterproof bearings with permanent lubrication. However, an additional watertight protection cap is also provided.

The curves can be with double disks for paths with two-way paths, or with a single disk for one-way paths.

The standard versions are: 30°-45°-60°-90°-180°.

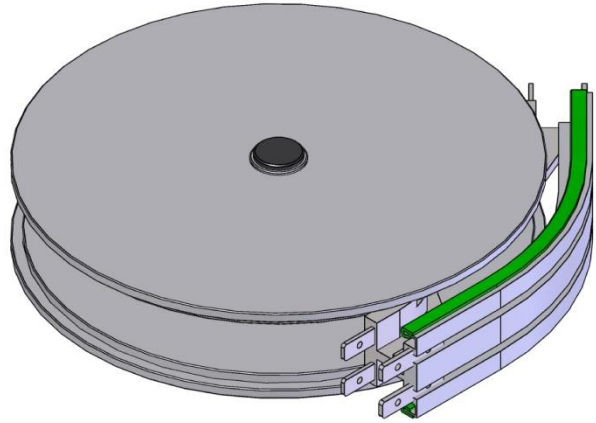

Article Number	Description	Article Code
1	IDLE DISK	BIDCF1
2	CHANNEL JOINING PLATE	BICF
3	CHANNEL CONNECTOR FORK	F5CP03
4	CHAIN SLIDEWAY	GS1
5	EXTERNAL FLAT CURVE	BIEIC(ANGOLO)
6	CHANNEL JOINING PLATE	PG1
7	CAP	F5CP05
8	BASE DISK WITH PIN FOR DOUBLE IDLE CURVE	F5CP02
9	BEARINGS	6004-2RS

The parts indicated are not sold separately unless they are present in this catalogue in the designated section.

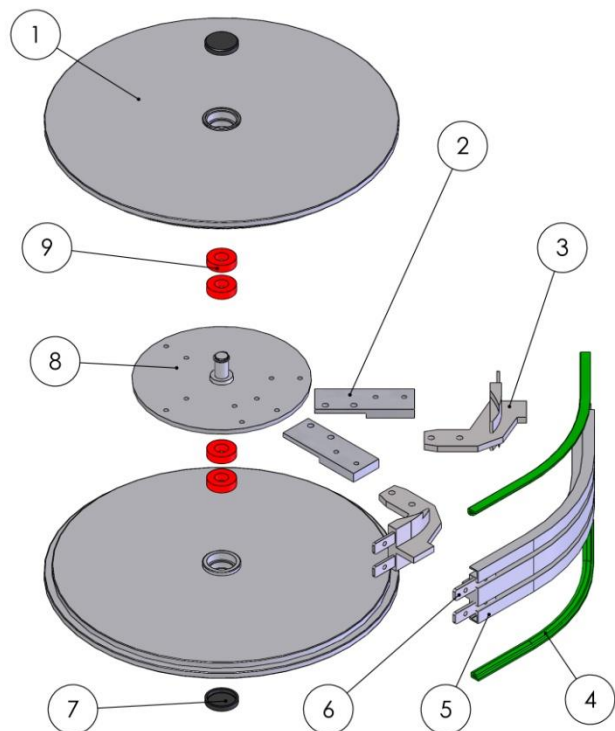

Flat curves with idle disk

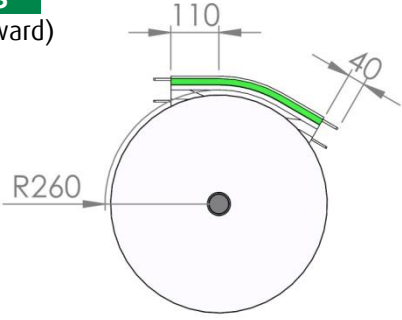
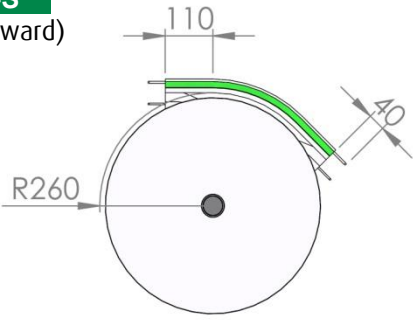
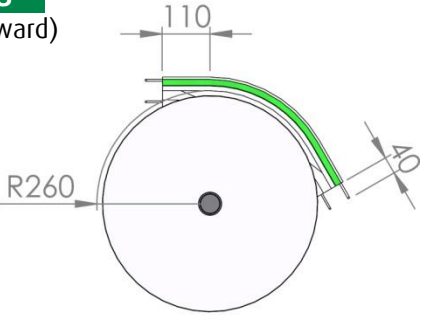
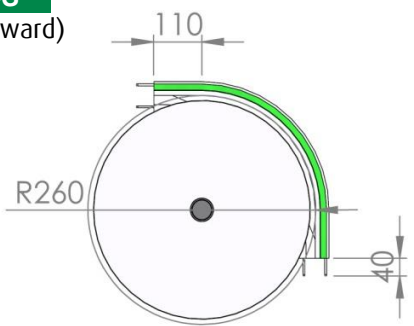
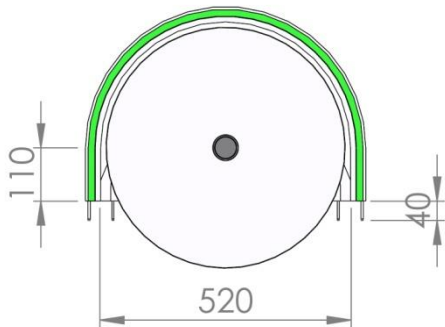
<p>30° CURVE</p> <p>Cod.: BI-CF30-D (double: forward and back)</p> <p>Cod.: BI-CF30-S (simple: only forward)</p> 	<p>45° CURVE</p> <p>Cod.: BI-CF45-D (double: forward and back)</p> <p>Cod.: BI-CF45-S (simple: only forward)</p> 
<p>60° CURVE</p> <p>Cod.: BI-CF60-D (double: forward and back)</p> <p>Cod.: BI-CF60-S (simple: only forward)</p> 	<p>90° CURVE</p> <p>Cod.: BI-CF90-D (double: forward and back)</p> <p>Cod.: BI-CF90-S (simple: only forward)</p> 
<p>180° CURVE</p> <p>Cod.: BI-CF180-D (double: forward and back)</p> <p>Cod.: BI-CF180-S (simple: only forward)</p> 	

Flat sliding curves

Flat sliding curves are used only in cases when it is necessary to contain the space on the sides, and therefore there is no option of installing the curve idle disk.

The standard versions are: 30°-45°-60°-90°-180°. On request, curves with different radii from the standard model can be built, such as very wide radius curves for very long products.

Sliding curves raise the chain's working tension. It is then necessary to consider this when designing the conveyor.

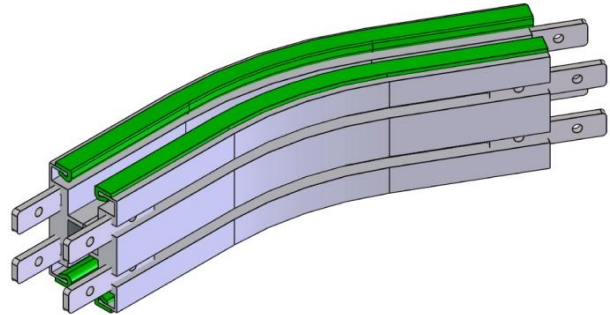

Article Number	Description	Article Code
1	EXTERNAL FLAT CURVE	BIEIC(ANGOLO)
2	CHAIN SLIDEWAY	GS1
3	JOINING PLATE	BICS01
4	EXTERNAL FLAT CURVE	BIEIC(ANGOLO)
5	CHAIN SLIDEWAY	GS1
6	CHANNEL JOINING PLATE	PG1

The parts indicated are not sold separately unless they are present in this catalogue in the designated section.

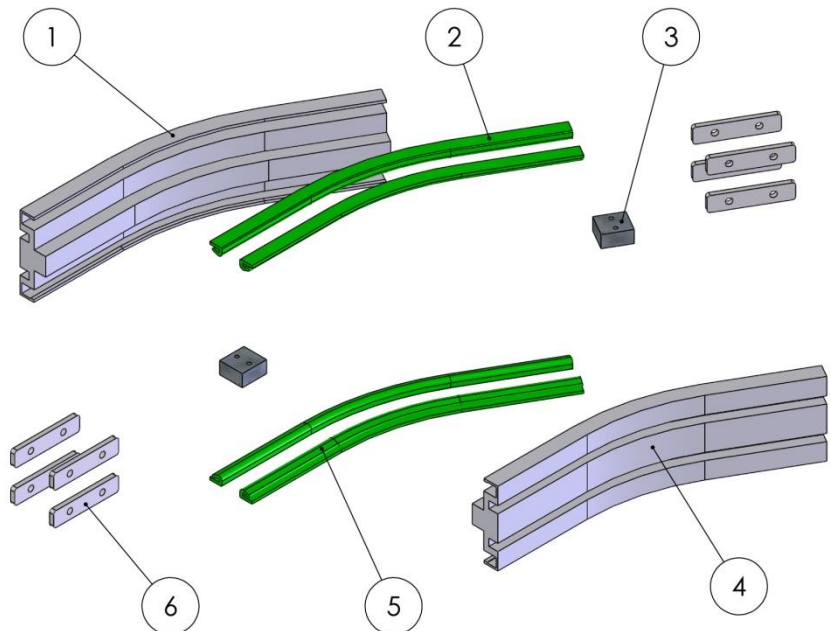

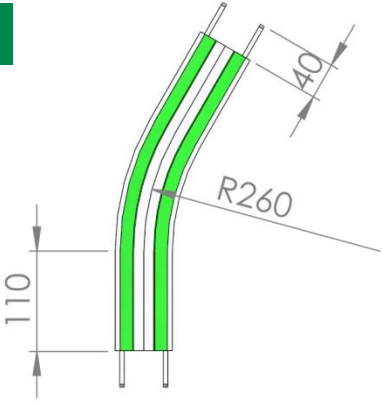
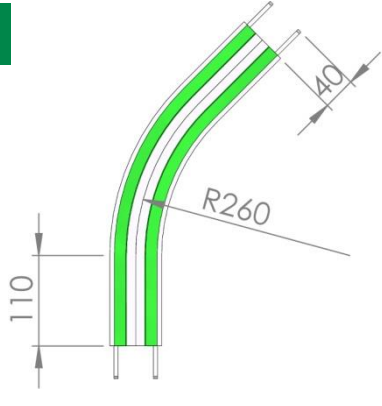
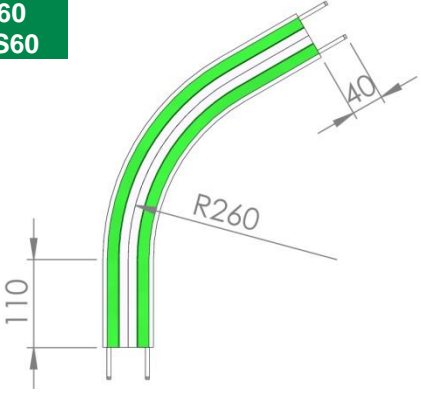
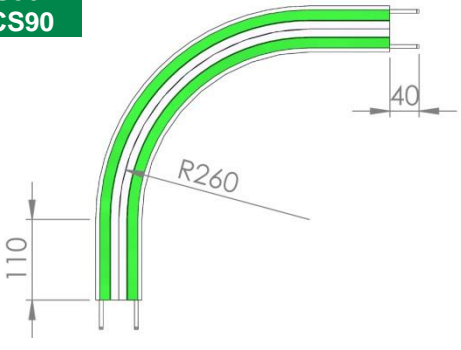
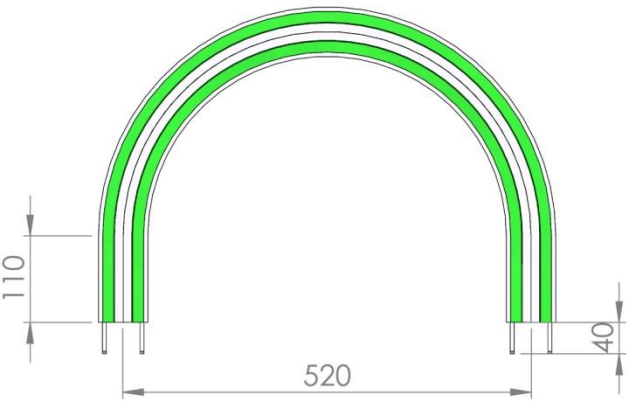

Flat sliding curves

<p>30° CURVE</p> <p>Cod.: BI-CS30 Inox: BIX-CS30</p> 	<p>45° CURVE</p> <p>Cod.: BI-CS45 Inox: BIX-CS45</p> 
<p>60° CURVE</p> <p>Cod.: BI-CS60 Inox: BIX-CS60</p> 	<p>90° CURVE</p> <p>Cod.: BI-CS90 Inox: BIX-CS90</p> 
<p>180° CURVE</p> <p>Cod.: BI-CS180 Inox: BIX-CS180</p> 	

Vertical sliding curves

This type of curve is used to form climbing or descending paths with slants that normally are greater than 11°. In these cases, the conveyor chain must have flights to ensure that the pieces are handled correctly. Vertical curves are made in satin finish stainless steel and are provided on specific request.

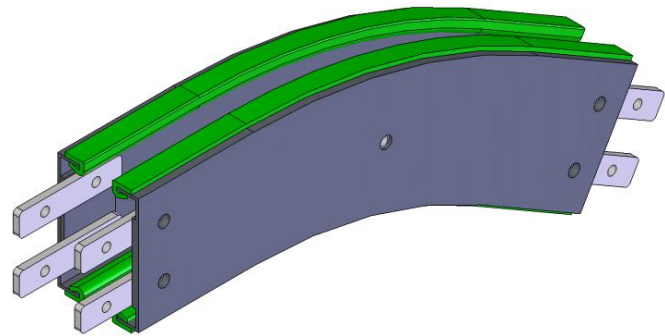

Article Number	Description	Article Code
1	SPACER	
2	SIDE	F5CSV(ANGLE)
3	CHANNEL JOINING PLATE	PG1
4	CHAIN SLIDEWAY	GS1

The parts indicated are not sold separately unless they are present in this catalogue in the designated section.

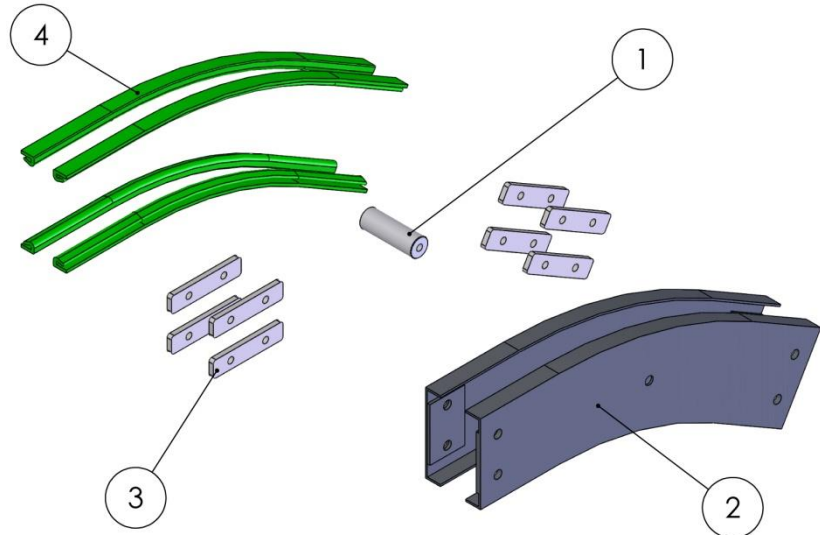

Vertical sliding curves

Note: For vertical curves up to 11°, the slope change is created with joining channel plates PG 4 (see page 8).

30° CURVE	
Cod.: BI-CSV30	
45° CURVE	
Cod.: BI-CSV40	
60° CURVE	
Cod.: BI-CSV60	
90° CURVE	
Cod.: BI-CSV90	

**SUMMARIZING TABLE OF ORDER CODES FOR CURVES**

Description	Order Code
Curve type	Flat curve with idle disk : BICF Flat sliding curve : BICS Vertical sliding curve : BICSV
Material	Standard Aluminum: Stainless Steel: X
Degrees	30 40 (standard only for vertical curves) 45 60 90 180 (In case of realization of curves with out of standard degrees, please insert required degrees)
Number of disks (Only for disk curves)	Single: S Double: D
Average Radius (Only in case of out of standard curves)	Specify average radius dimension in mm

Example of standard curve order code:

30° Flat curve with double idle disk
Cod: BICF-30-D

Example of out of standard curve order code:

15° Vertical sliding curve with a average radius of 500 mm
Cod: BICSV-15-R500



Lateral guides

Biflex is an open system that allows to use several types of supports and lateral guides found on the market.

The guides shown below can be either fixed or adjustable, depending on client needs.

The corresponding data are correlated to a basic guide format: on request, accessories to increase flexibility are available.

For more technical information and evaluations, please contact our Technical Office.

Making guides in curves are no problem when using fixed guides.

For adjustable guides for curves, please contact our Technical Office.

Fixed guides

BI GPF1

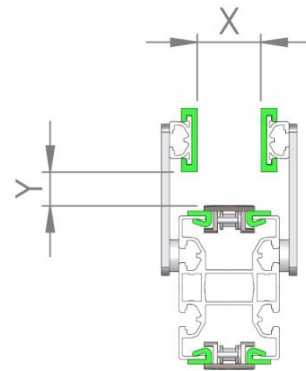
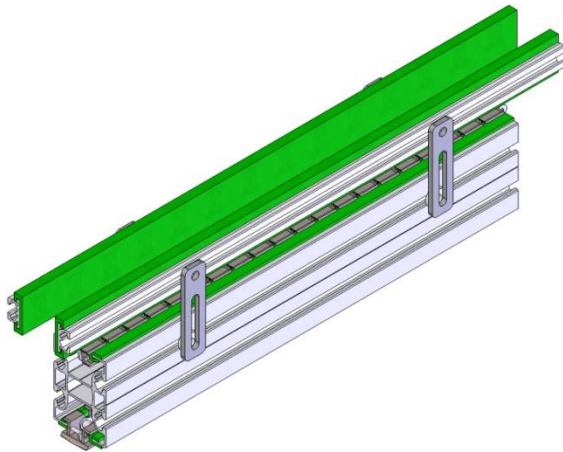

Composition (per channel meter):

GL40P	: 2 m
GL30A	: 2 m
DS2010A6/16/26	: 4 pieces
PSG95	: 4 pieces

Clearance:

X	: 40 mm minimum*
Y	: 3 ÷ 19 mm*

* The X dimension changes with the length of the aluminum spacer.

The Y dimension varies through the slot in the PSG95 plate.

BI GPF3

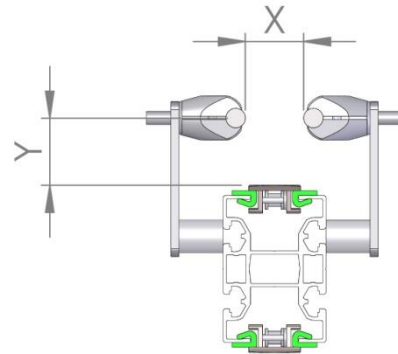
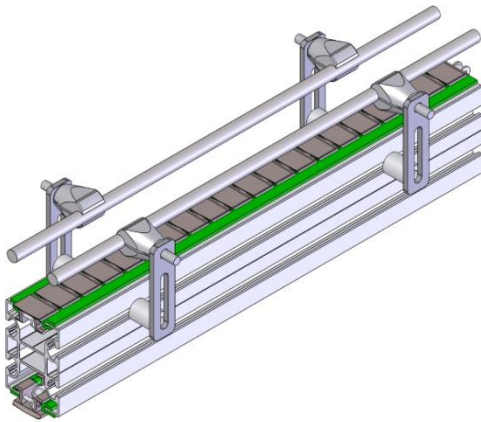

Composition (per channel meter):

GL12SS	: 2 m
MGT12	: 4 pieces
DS2010A27/37/47	: 4 pieces
PSG95	: 4 pieces

Clearance:

X	: 37 mm minimum*
Y	: 15 ÷ 39 mm*

* The X dimension changes with the length of the aluminum spacer.
The Y dimension varies through the slot in the PSG95 plate.

BI GPF4

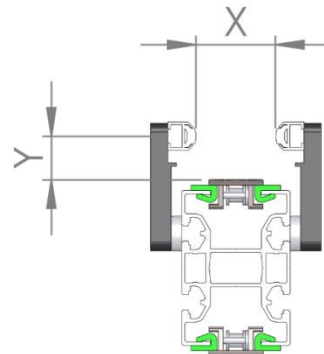
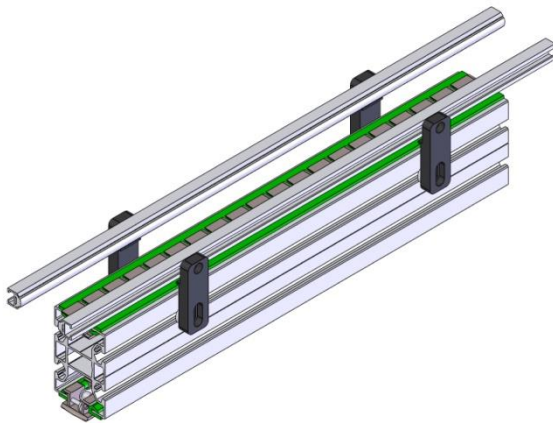

Composition (per channel meter):

GL16PA	: 2 m
DS2010A6/16/26	: 4 pieces
PSG10	: 4 pieces

Clearance:

X	: 47 mm minimum*
Y	: 10 ÷ 24 mm*

* The X dimension changes with the length of the aluminum spacer.
The Y dimension varies through the slot in the PSG10 plate.



BI GPF6

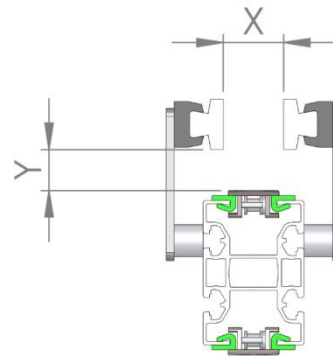
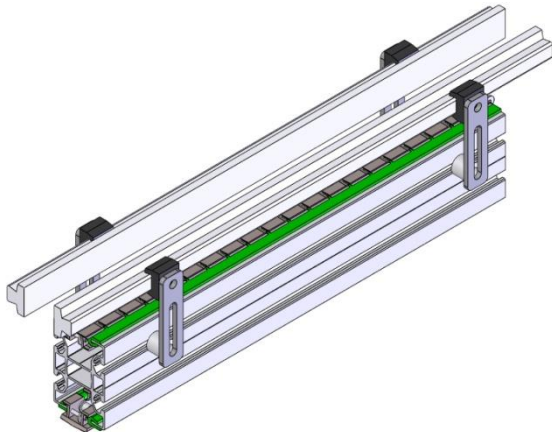

Composition (per channel meter):

GL31SS	: 2 m
MGL31SS	: 4 pieces
DS2010A18/28/38	: 4 pieces
PSG95	: 4 pieces

Clearance:

X	: 37 mm minimum*
Y	: 3 ÷ 23 mm*

* The X dimension changes with the length of the aluminum spacer.
The Y dimension varies through the slot in the PSG95 plate.

Adjustable guides

BI GPR4

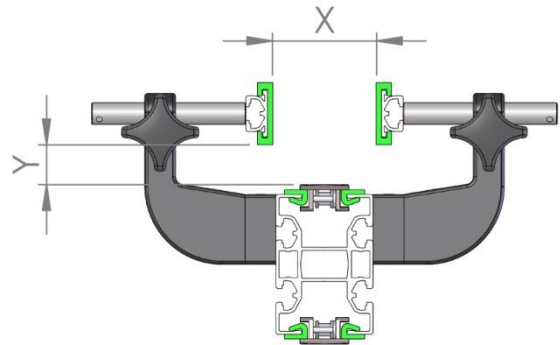
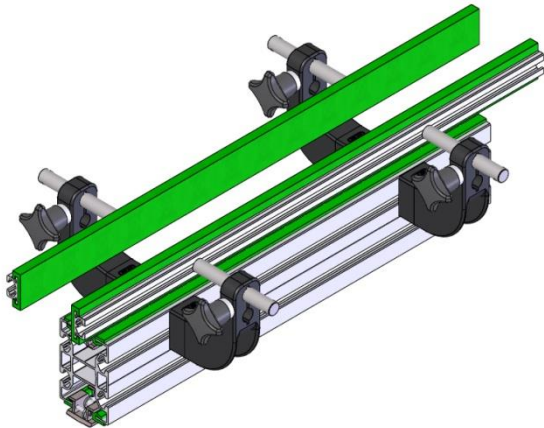

Composition (per channel meter):

GL40P	: 2 m
GL30A	: 2 m
SG11	: 4 pieces
DS11	: 4/8/12 pieces
PFG14	: 4 pieces

Clearance:

X	: 7 ÷ 59 mm*
Y	: 13 ÷ 35 mm*

* The X dimension depends on the number of DS11 spacers used and the adjustment provided by the PFG14 pin.

The Y dimension is Y varies through the slot in the SG11 support and on the DS11 spacer.

BI GPR6

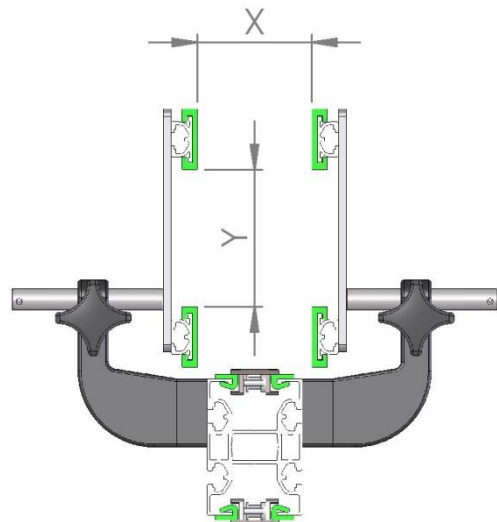
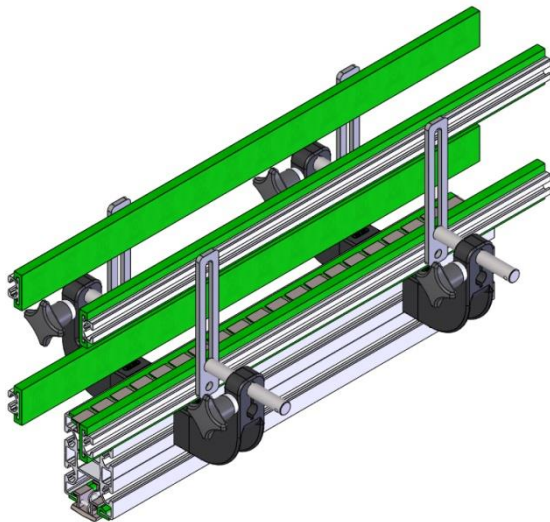

Composition (per channel meter):

GL40P	: 4 m
GL30A	: 4 m
SG11	: 4 pieces
DS11	: 4/8/12 pieces
PFG14	: 4 pieces
PSG160	: 4 pieces

Clearance:

X	: 7 ÷ 59 mm*
Y	: 0 ÷ 98 mm*

* The X dimension depends on the number of DS11 spacers used and the adjustment provided by the PFG14 pin.

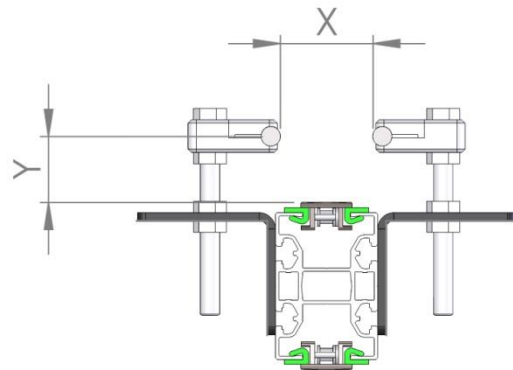
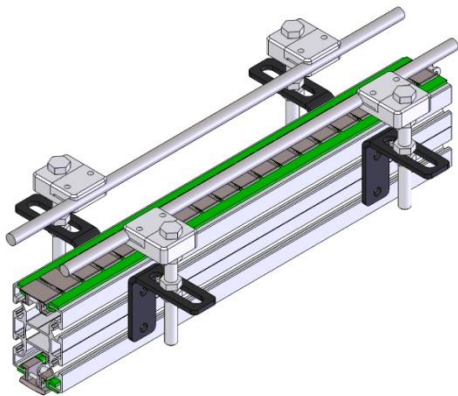
**BI GPR7****Composition (per channel meter):**

GL12SS	: 2 m
M240-241	: 4 pieces
Bracket 244	: 4 pieces
Screws M12x120	: 4 pieces
PS6020 20/40/60	: 4 pieces

Clearance:

X	: 17 ÷ 96 mm*
Y	: 26 ÷ 80 mm*

* The X dimension changes with the slot on the 244 bracket.
The Y dimension can be adjusted with the support screws.

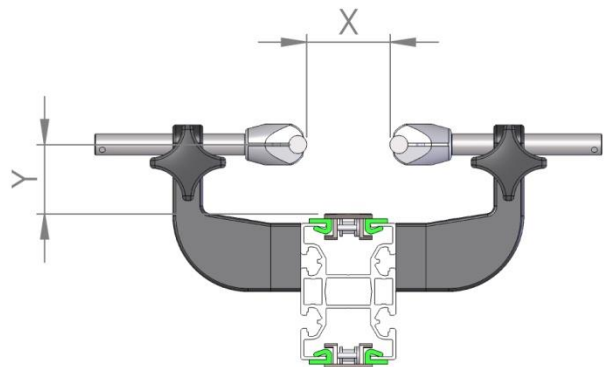
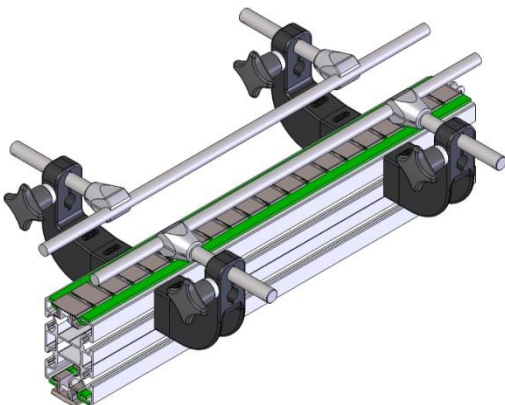
BI GPR11**Composition (per channel meter):**

GL12SS	: 2 m
MGT12	: 4 pieces
SG11	: 4 pieces
SG11DS11	: 4/8/12 pieces
PFG14	: 4 pieces

Clearance:

X	: 7 ÷ 67 mm*
Y	: 33 ÷ 55 mm*

* The X dimension depends on the number of DS11 spacers used and the adjustment provided by the PFG14 pin.
The Y dimension is Y varies through the slot in the SG11 support and on the DS11 spacer.

BI GPR17

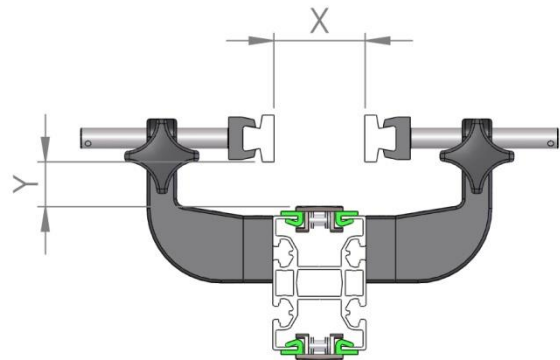
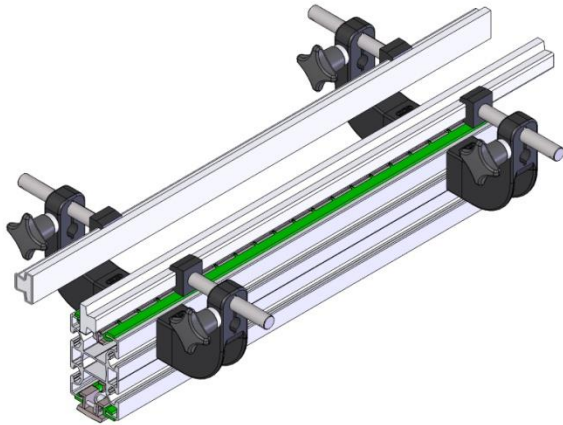

Composition (per channel meter):

GL315S	: 2 m
MGL315S	: 4 pieces
SG11	: 4 pieces
DS11	: 4/8/12 pieces
PFG14	: 4 pieces

Clearance:

X	: 7 ÷ 47 mm*
Y	: 17 ÷ 39 mm*

* The X dimension depends on the number of DS11 spacers used and the adjustment provided by the PFG14 pin.
The Y dimension is Y varies through the slot in the SG11 support and on the DS11 spacer.

BI GPR18

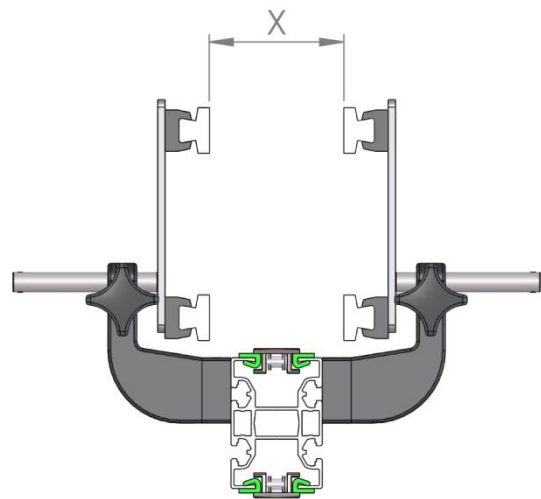
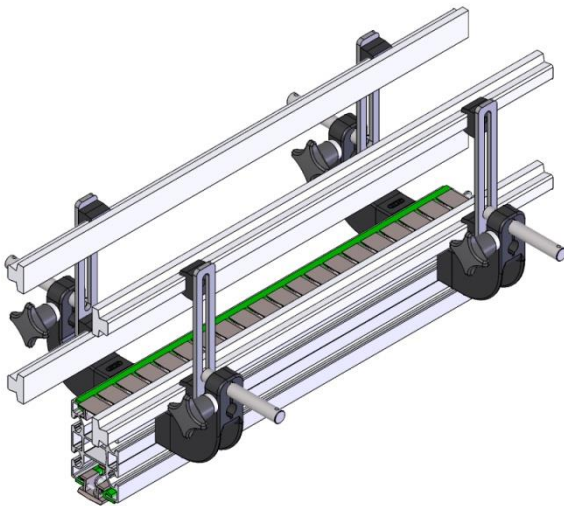

Composition (per channel meter):

GL315S	: 4 m
MGL315S	: 8 pieces
SG11	: 4 pieces
DS11	: 4/8/12 pieces
PFG14	: 4 pieces
PSG160	: 4 pieces

Clearance:

X	: 7 ÷ 47 mm*
---	--------------

* The X dimension depends on the number of DS11 spacers used and the adjustment provided by the PFG14 pin.



Lateral guides accessories

Support

Material : Polyamide
 Colour : Black
 Packaging : 10 pieces

Order Code: SG11

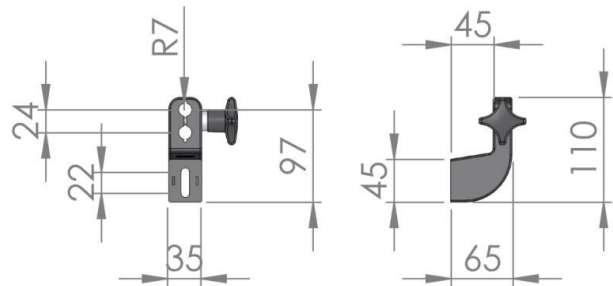

Guide fastening pin

Material : Stainless steel
 Packaging : 10 pieces

Order Code: PFG14

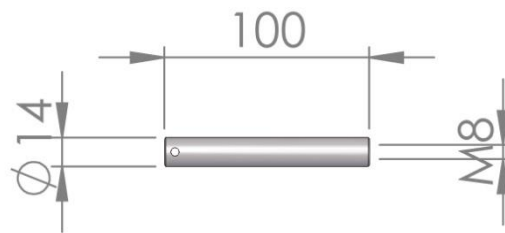

Support spacer

Material : Polyamide
 Colour : Black
 Packaging : 10 pieces

Order Code: DS11

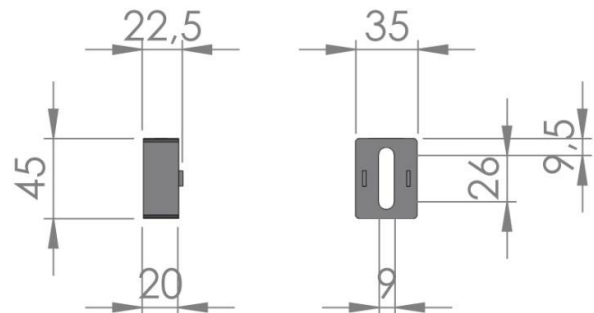

Material : Anodized aluminum
 Packaging : Custom cut into bars

Order Code: DS2010A

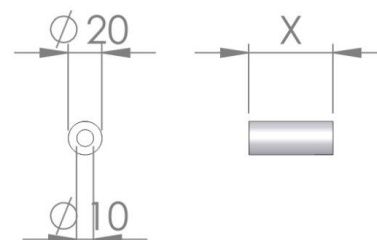



Guide support clamps

Material : Polyamide
Colour : Black
Packaging : 10 pieces

Order Code: MGT12

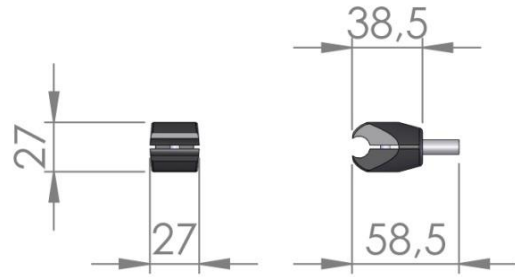

Material : Polyamide
Colour : Black
Packaging : 20 pieces with bolts

Order Code: MGL31SS

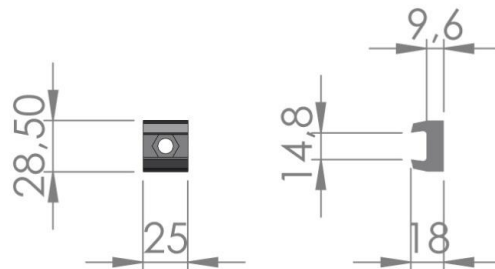

Material : Aluminum
Packaging : 10 pieces

Order Code: MGTB

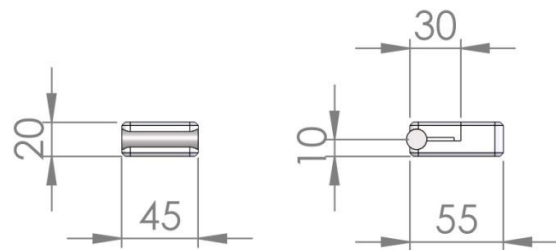

Material : Stainless steel
Packaging : 10 pieces

Order Code: PSG95

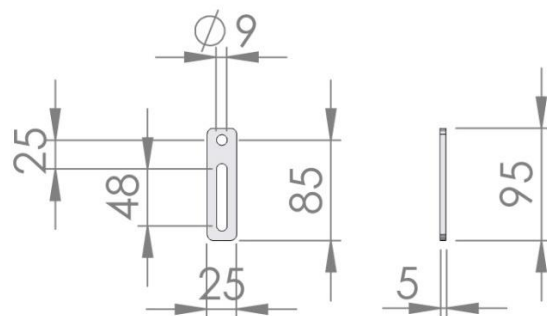



Material : Stainless steel
Packaging : 10 pieces

Order Code: PSG160

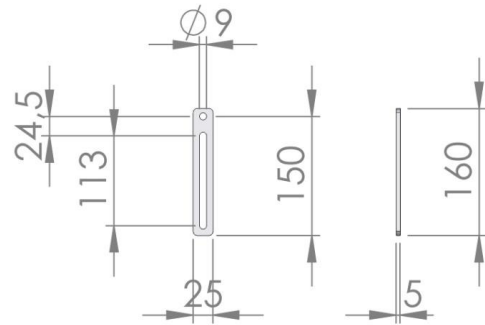

Material : Polyamide
Colour : Black
Packaging : 10 pieces

Order Code: PSG10

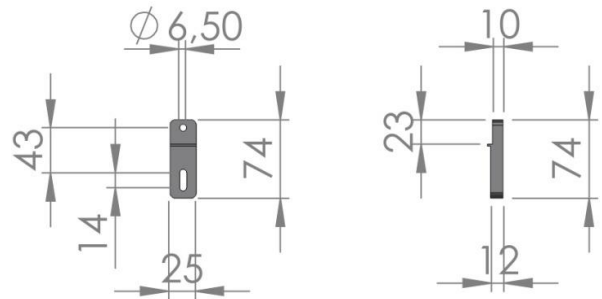

Profiles

Material : Polyethylene
Colour : Green
Length : 3 m

Order Code: GL40P

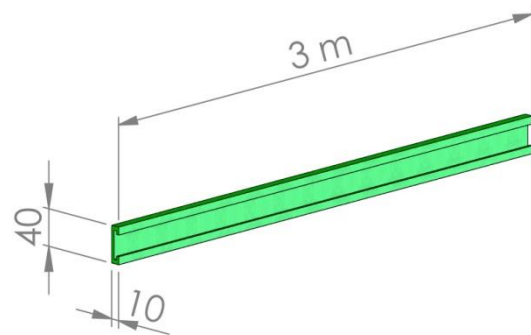

Material : Anodized aluminum
Length : 6 m

Order Code: GL30A

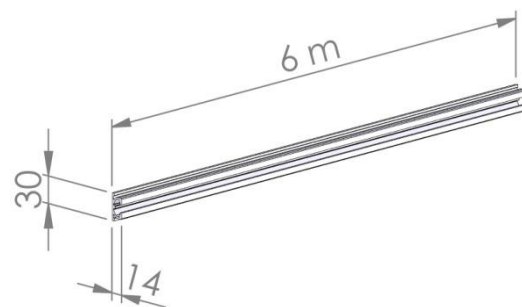



Material : Stainless steel and Polyamide
Colour : White
Length : 3 m

Order Code: GL31SS

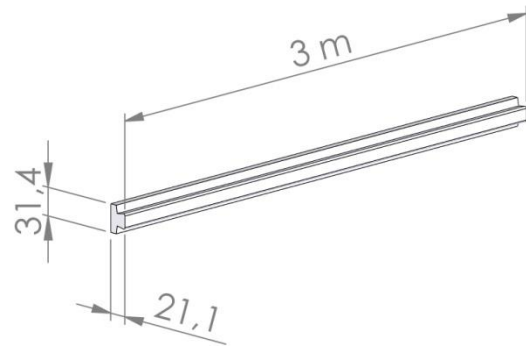

Material : Stainless steel
Length : 3/6 m

Order Code: GL12SS

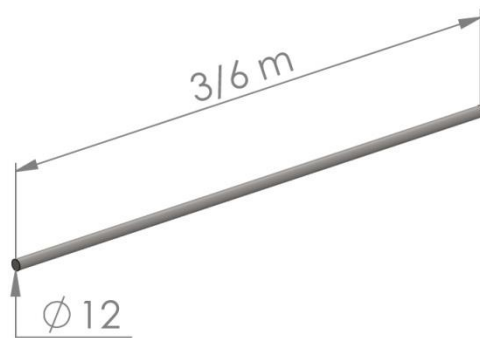

Material : Anodized aluminum and Polyamide
Colour : White
Length : 3 m

Order Code: GL16A

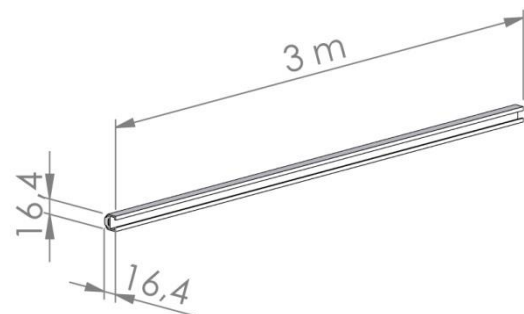



Intermediate guide (GLP40) clamps

Material : Polyamide
Colour : Black
Packaging : 10 pieces with screws

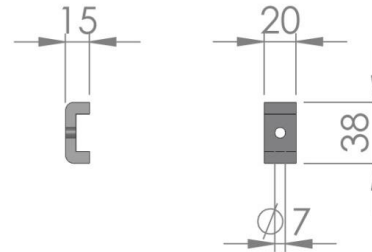

Order Code: MBPI

Guide (GLP40) clamp for curves

Material : Polyamide
Colour : Black
Packaging : 10 pieces with screws

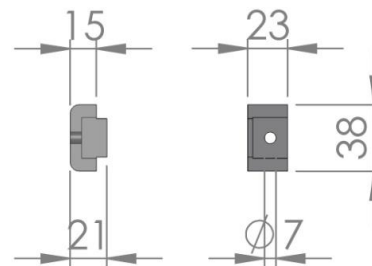

Order Code: MBPC

Terminal guide (GLP40) clamp

Material : Polyamide
Colour : Black
Packaging : 10 pieces with screws

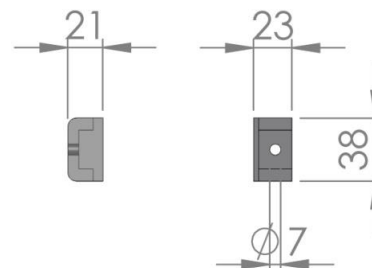

Order Code: MBPT

Guide joining plate

Material : Galvanized steel
 Stainless steel
Packaging : 50 pieces with bolts

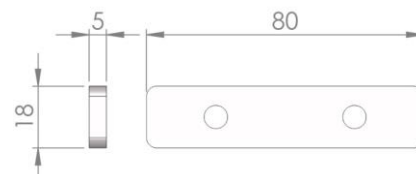

Order Code: PG1

Stainless Steel Version: PGX1



Double tracks BIFLEX conveyor

Biflex compact structure is particularly suitable for the realization of double tracks conveyors. The two tracks are joined with some spacer made with our aluminum profile PS8040, posed at pace of 1000 mm. Spacer dimensions vary according to the axle spacing between the tracks.

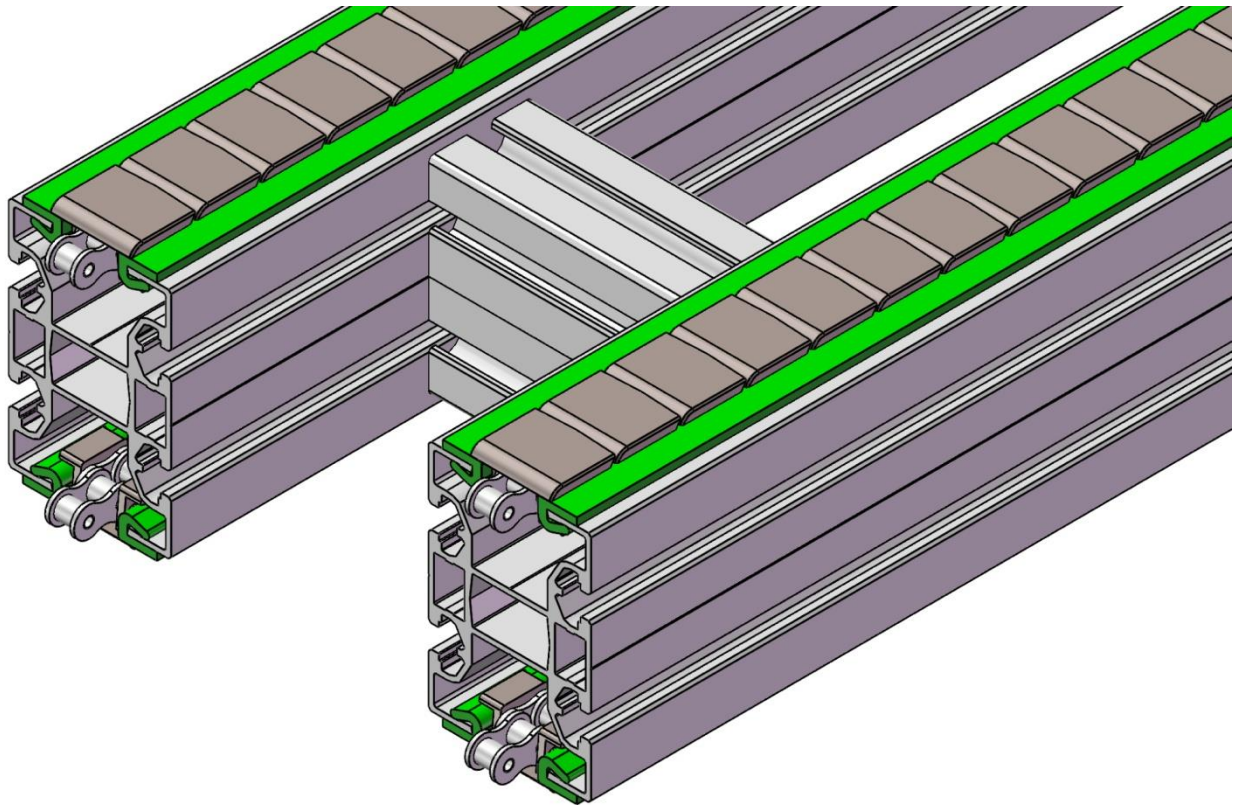

Double tracks spacer

Material : Anodized aluminum

Length : 3÷6 meters in bars

Order Code: PS8040

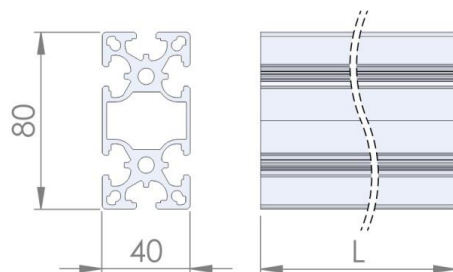

Motor drives for double tracks BIFLEX conveyor

For double tracks conveyors, every track has its own motorization drive. The two motorization drives are connected by a passing shaft on which is engaged a single motor gear.

Suspended end motor drive

The end drive is the most used to make conveyors of any shape with forward and backward paths. The most natural configuration for a conveyor belt is with the motor drive "pulling" the chain.

The unit is mounted on the side of the motor and is directly connected to the chain drive sprocket.

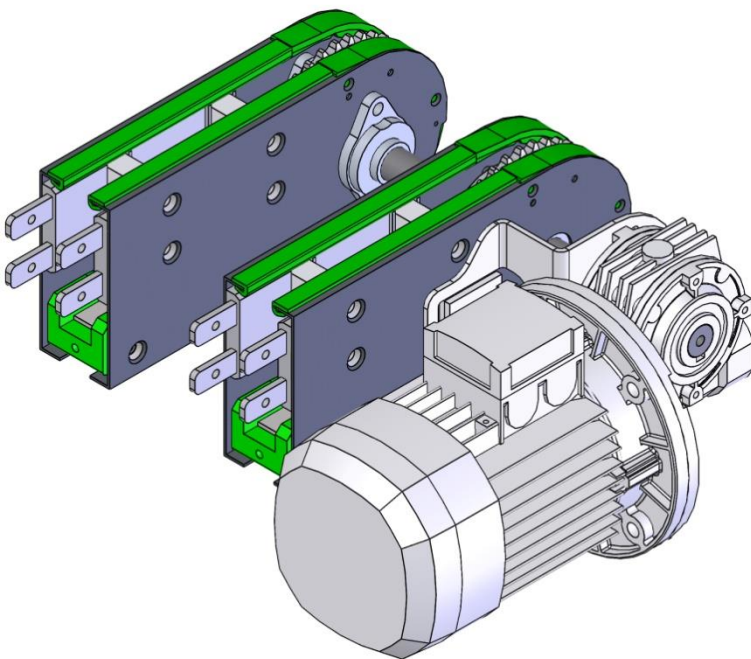

Technical specifications:

Standard motor	:	Triphase 220/380 V
N° teeth drive sprocket	:	Z 25 Dp. 153 mm
Standard speed at 50 Hz (m/min)	:	6.5, 14, 23, 35.5, 64

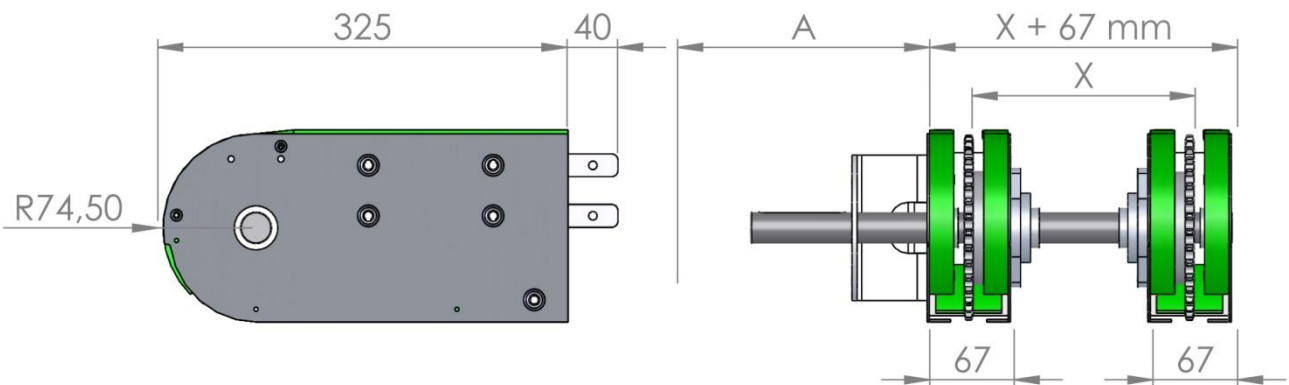

X = Axle spacing between the tracks
 Volume depending to the motor gear type = A+X+67 mm

Suspended end motor drive with guided chain

The unit is mounted on the side of the motor and is directly connected to the chain drive sprocket. This type of head can be used for applications with transporters of limited lengths or that run at high speeds. If combined with a tensioned return head (contact the technical office for this special execution) it can "push" the conveyor.

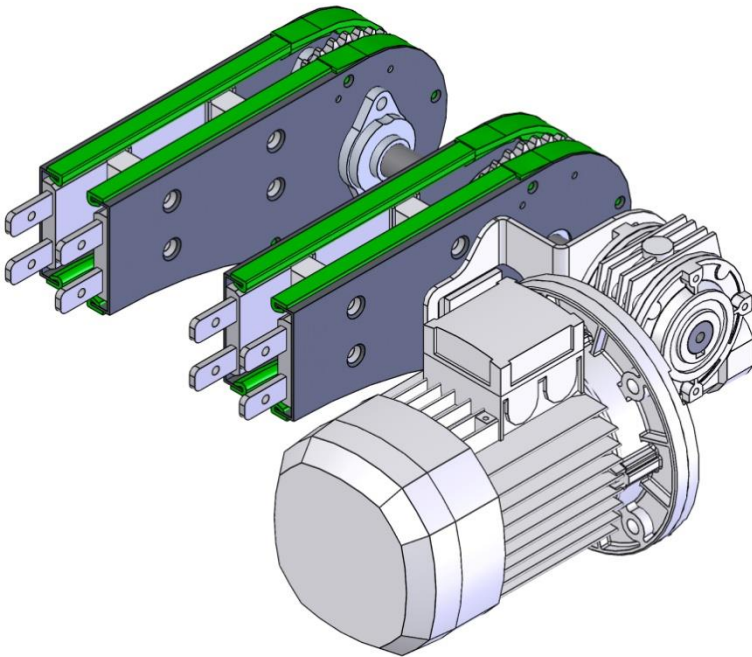

Technical specifications:

Standard motor	:	Triphase 220/380 V
N° teeth drive sprocket	:	Z 25 Dp. 153 mm
Standard speed at 50 Hz (m/min)	:	6.5, 14, 23, 35.5, 64

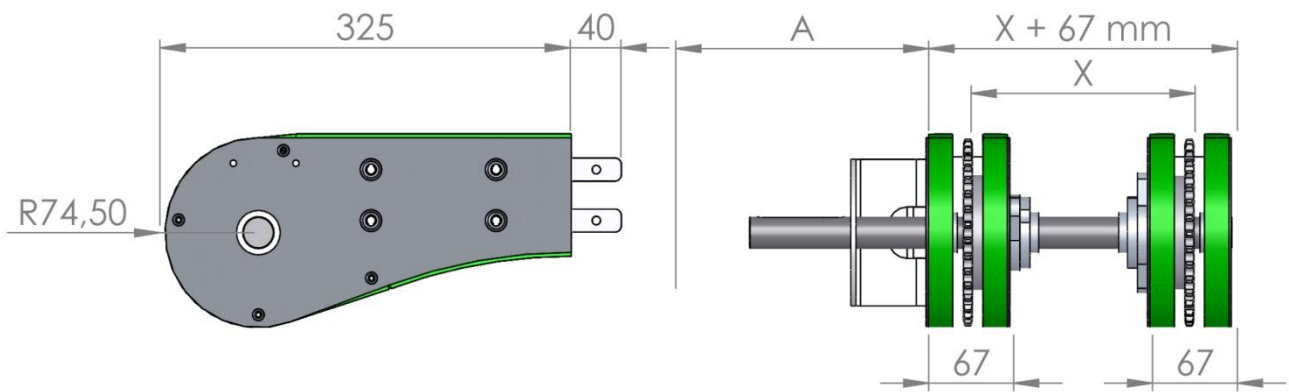

X = Axle spacing between the tracks
 Volume depending to the motor gear type = $A + X + 67$ mm

Transferred end motor drive

The transferred drive kit allows to move the position of the gear motor with respect to the axis of the drive sprocket. These are commonly used when it is necessary to reduce the space occupied by the end motor drive unit.

Transmission chain tension is regulated by using the available space in the slots on the support plate of the motor unit. The transmission has a suitable safety protection which must always be in its place when the conveyor is moving.

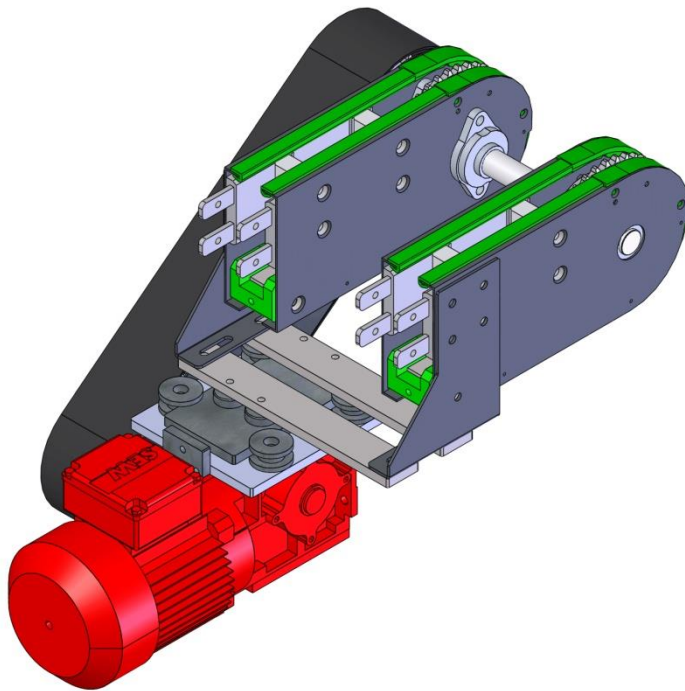

Technical specifications:

Standard motor	: Triphase 220/380 V
N° teeth drive sprocket	: Z 25 Dp. 153 mm
Standard speed at 50 Hz (m/min)	: 6.5, 14, 23, 35.5, 64

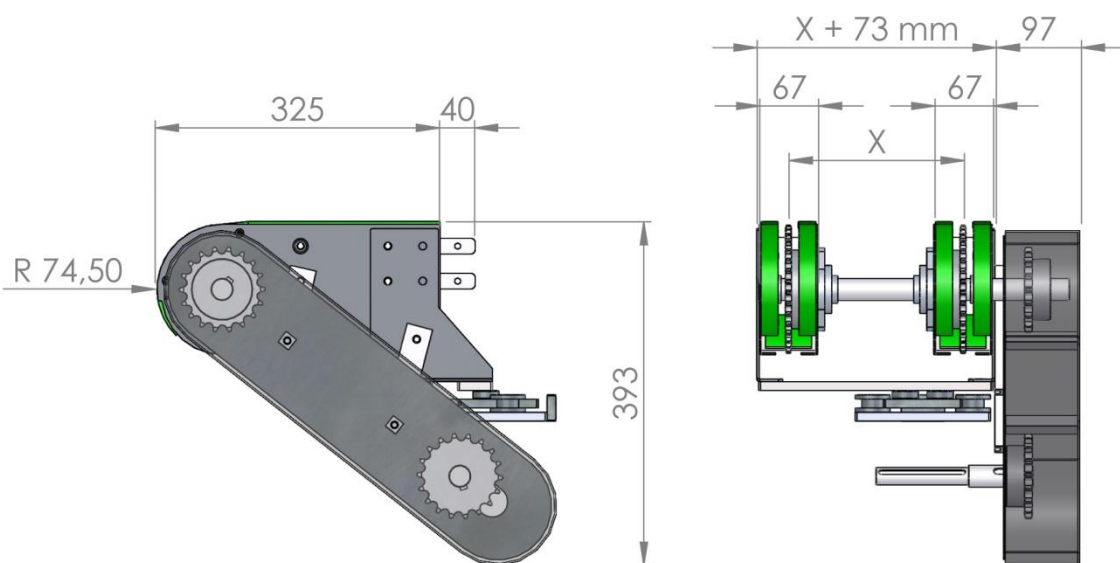

X = Axle spacing between the tracks

Transferred end drive with guided chain

The transferred drive kit allows to move the position of the gear motor with respect to the axis of the drive sprocket. These are commonly used when it is necessary to reduce the space occupied by the end motor drive unit.

Transmission chain tension is regulated by using the available space in the slots on the support plate of the motor unit. The transmission has a suitable safety protection which must always be in its place when the conveyor is moving.

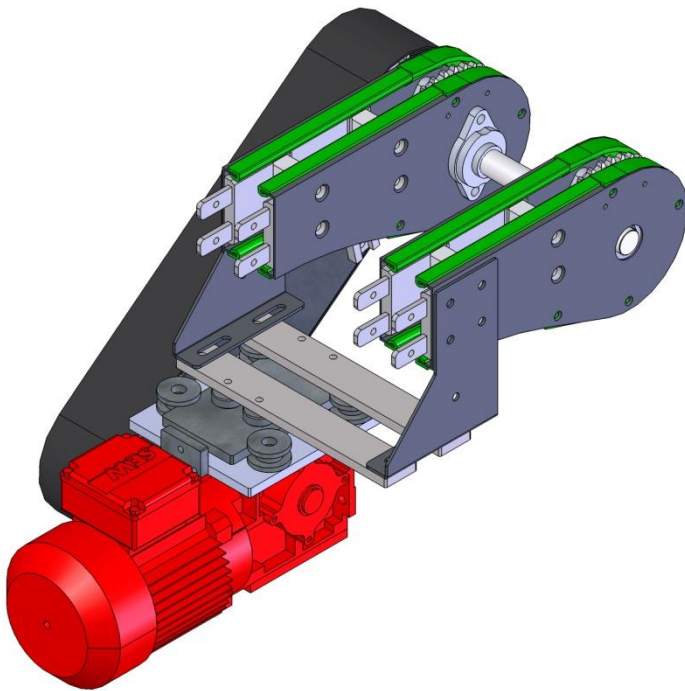

Technical specifications:

Standard motor : Triphase 220/380 V

N° teeth drive sprocket : Z 25 Dp. 153 mm

Standard speed at 50 Hz (m/min) : 6.5, 14, 23, 35.5, 64

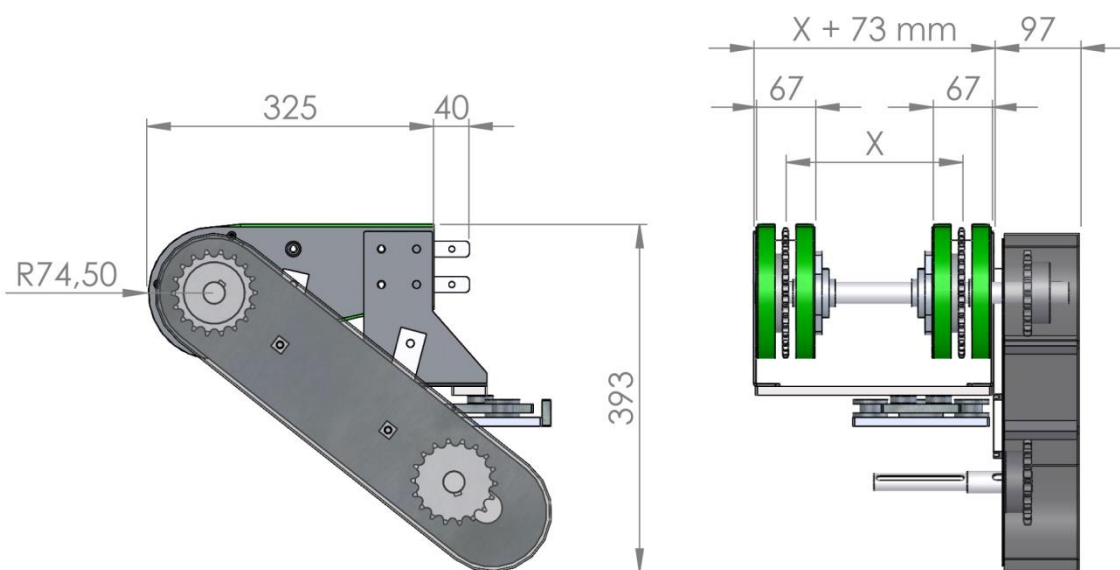

X = Axle spacing between the tracks

Central suspended motor drive

The central motor drive can be installed at any point along the conveyor. It is normally used when the conveyor has a closed ring configuration. The best working conditions are obtained by positioning the drive as closely as possible to the point in where the greatest load is situated. Central drive considers also a roller passage to facilitate the transport continuity.

The unit is mounted on the side of the motor and is directly connected to the chain drive sprocket.

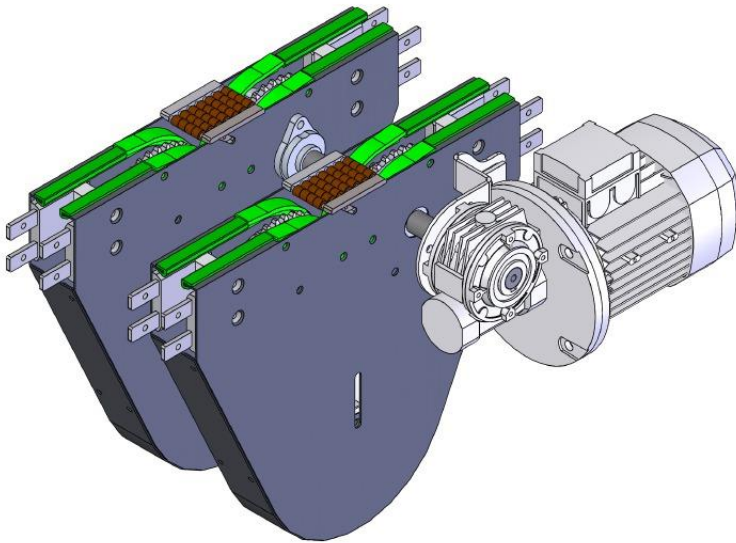

Technical specifications:

Standard motor	: Triphase 220/380 V
N° teeth drive sprocket	: Z 25 Dp. 153 mm
Standard speed at 50 Hz (m/min)	: 6.5, 14, 23, 35.5, 64

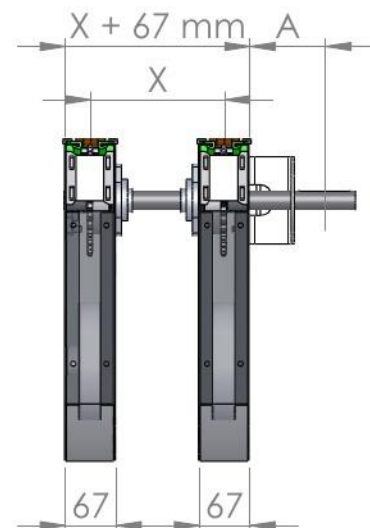
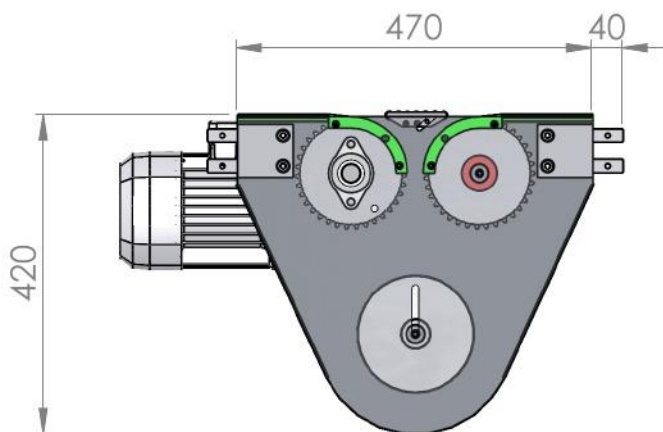

X = Axle spacing between the tracks

HOW TO WRITE THE ORDER CODES FOR MOTOR DRIVES FOR DOUBLE TRACKS BIFLEX CONVEYOR

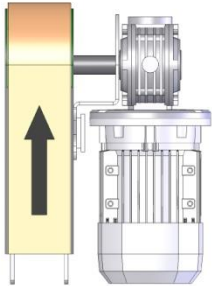
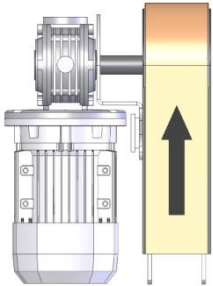
Description	Order Code	
Motor drive type	Double suspended end : BIMPD Double transferred end : BIMRD Double suspended end with guided chain : BIMPCGD Double transferred end with guided chain : BIMRCGD Double central suspended : BIMCPD	
Drive side	Right: D 	Left: S 
Motor gear type	Bonfiglioli MVF49 Bonfiglioli W63 SEW WA20 SEW WA30	
Motor gear presence	Yes: Y No: N	
Axle spacing between the tracks	L follows by the axle spacing between the tracks	

If purchasing the drive unit with your order, please specify the required speed at the time of ordering.

Example:

Double right suspended end motor drive with SEW WA30 motor gear included and a distance of 200 mm between the tracks

Cod: BIMP-D-WA30-Y-L200

NOTE: For speeds above 20 m/min or in the presence of frequent starts or high loads, it is essential to put the motors under soft starter or inverter



Standard returns for double tracks BIFLEX conveyor

There are different standard return units to choose from depending on the construction requirements of the conveyor, for speeds of up to 70m/min. Every return unit has a chain guide around the entire track, to prevent the lower part from derailing.

180° Long final return

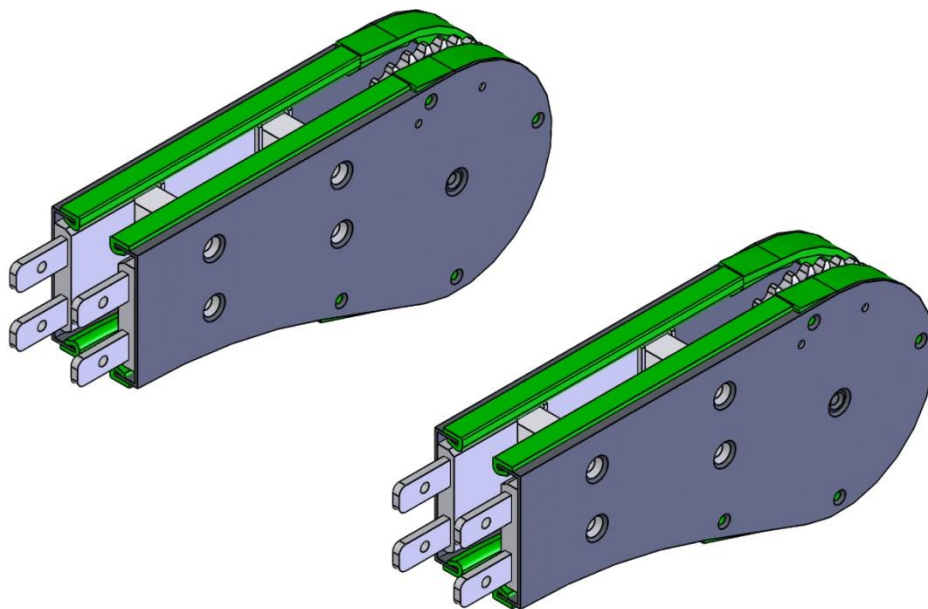
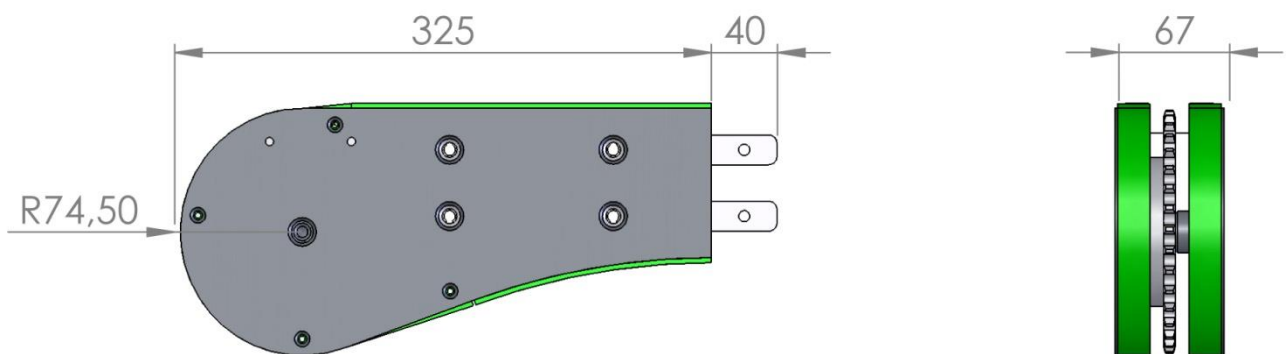

Order Code: BIRLD



180° Short final return

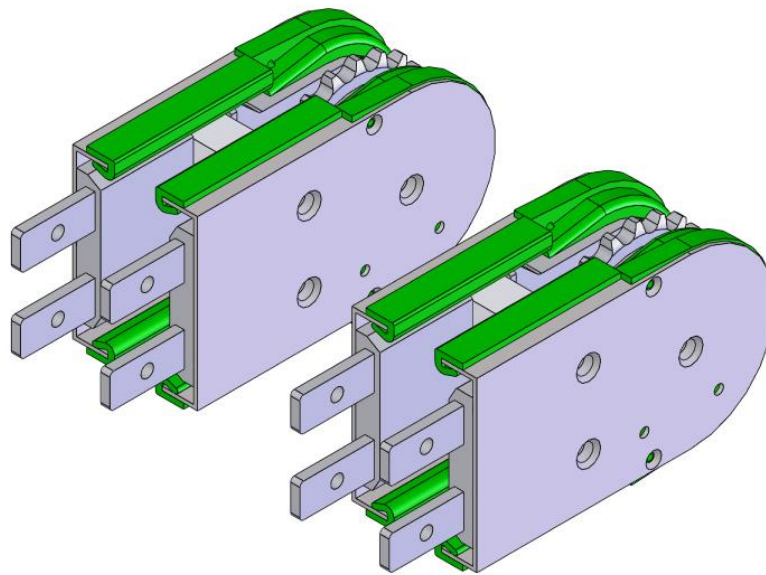
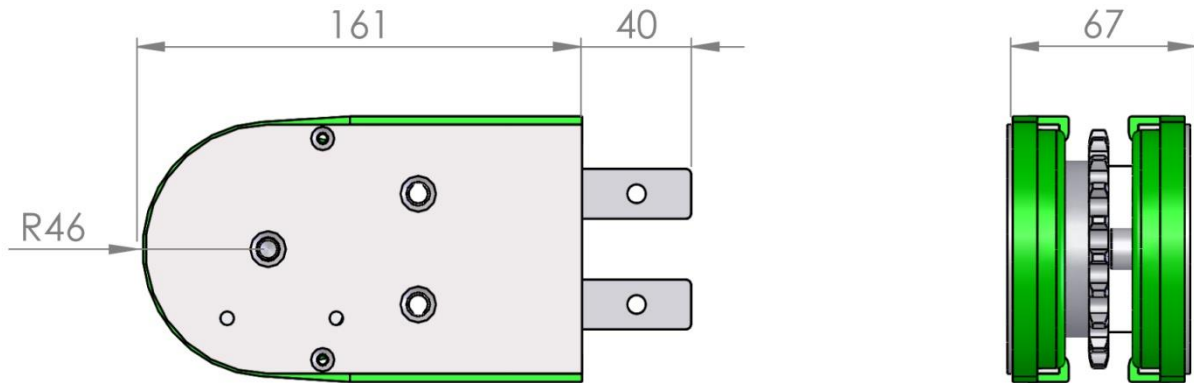

Order Code: BIRCD



Double tracks flat sliding curves

30° CURVE

Cod.: BI-CSD30
Inox: BIX-CSD30

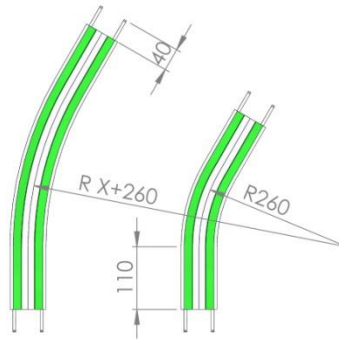

45° CURVE

Cod.: BI-CSD45
Inox: BIX-CSD45

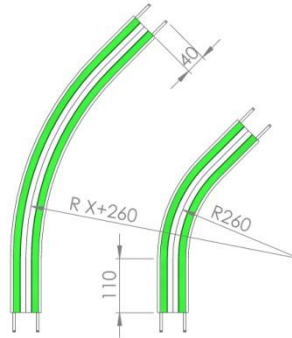

60° CURVE

Cod.: BI-CSD60
Inox: BIX-CSD60



90° CURVE

Cod.: BI-CSD90
Inox: BIX-CSD90

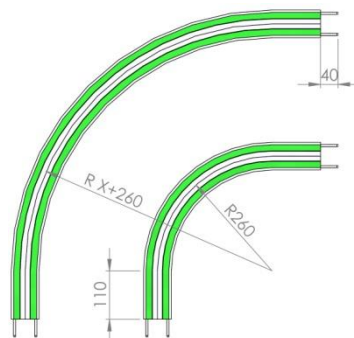

180° CURVE

Cod.: BI-CSD180
Inox: BIX-CSD180

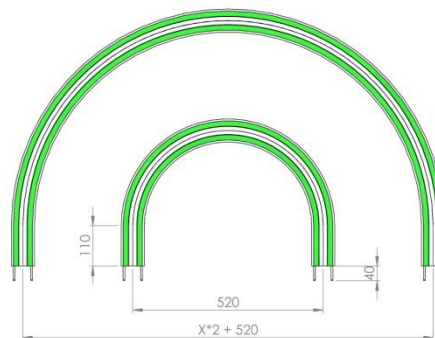



SUMMARIZING TABLE OF ORDER CODES FOR DOUBLE TRACKS FLAT SLIDING CURVES

Description	Order Code
Curve type	Double tracks flat sliding curve : BICSD
Material	Standard Aluminum: Stainless Steel: X
Degrees	30 45 60 90 180 (In case of realization of curves with out of standard degrees, please insert required degrees)
Average Internal track radius (Only in case of out of standard curves)	Specify average radius dimension in mm
Axle spacing between the tracks	L follows by the axle spacing between the tracks

Example of standard curve order code:

30° Double tracks flat sliding curve with 200 mm axle spacing between the tracks

Cod: BICSD-30-L200

Example of out of standard curve order code:

15° Double tracks flat sliding curve with average internal track radius 300 mm and 200 mm axle spacing between the tracks

Cod: BICSD-15-R300-L200



Conveyor support systems

BI S1D

BIS1D system support is composed of a double two-legged base in polyamide with adjustable feet, linked with a stainless steel tubular.

The bases are surmounted by 2 stainless steel tubulars and at the top of them are welded 2 brackets to support the conveyor channel. The channel is fastened directly on the brackets using the holes or the cavities on the side of the profile. The height of the conveyor can be adjust also with the regulation of the tubular.

His conformation makes it suitable only for double tracks conveyors.

Standard feet don't have the anti vibrations rubber, but they can be predispose with the holes to fix the conveyor to the ground. The model can be also assemble with wheels with brake.

The height of the conveyor chain plan can be adjust between a standard regulation of ± 70 mm: the wheels version hasn't got regulation.

For the realization of support with a height not included in this standard range or with a wider regulation, please contact our Technical Department



Composition:

Stainless steel Ø 48 mm tubular	
GF70	: 1 piece
PSR60	: 3 pieces

Order Code: BIS1D



Composition:

Stainless steel Ø 48 mm tubular	
GF70	: 2 pieces
RP80	: 3 pieces

Order Code: BIS1DR



BIS1D



X = required chain level
Y = L+61 mm

(where L is the axle spacing between the tracks)

BIS2D – BIS5D

BIS2D and BIS5D systems support are composed of a two-legged frame built with a painted iron or stainless steel square tubular of two different dimensions:

- 40x40 mm for BIS2D system
- 50x50 mm for BIS5D system

The feet at the base of the frame are in polyamide and are adjustable in height, with a maximum of ± 50 mm. The 2 brackets for the support of the conveyor channel are welded directly on the frame. The channel is fastened on the brackets using the holes or the cavities on the side of the profile, so the distance between the brackets is the width of the channel.

Both the models are suitable for single or double tracks conveyor: the frame will be custom built with the necessary size.

Standard feet don't have the anti vibrations rubber, but they can be predispose with the holes to fix the conveyor to the ground. Both the models can be assemble with wheels with brake: these models haven't got regulation.

For the realization of support with a height not included in this standard range or with a wider regulation, please contact our Technical Department

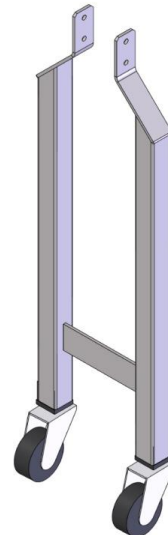
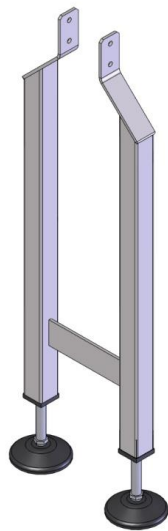

Composition:

Square tubular frame 40x40 mm
PSR100

: 2 pieces

Composition:

Square tubular frame 40x40 mm
RP80

: 2 pieces

Order Code: BIS2D

Order Code: BIS2DR

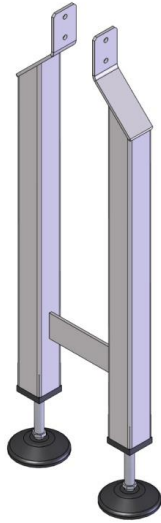

Composition:

Square tubular frame 50x50 mm
PSR100

: 2 pieces

Order Code: BIS5D

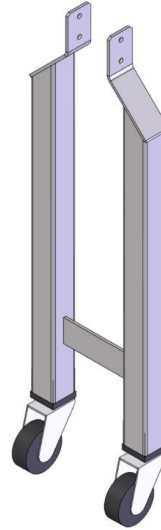

Composition:

Square tubular frame 50x50 mm
RP80

: 2 pieces

Order Code: BIS5DR

BIS2D	BIS5D
<p>X = required chain level</p>	<p>X = required chain level</p>

**BIS3**

F5S3 system supports are composed of a frame built with a anodized aluminum profile of different dimensions:

- 80x40 mm for BIS3 system
- 40x40 mm for BIS3D system

F5S3 system support is composed of a single-legged frame on which are screwed 2 brackets to support the channel and is suitable for single track conveyors.

The base of the frame is in galvanized steel and is adjustable in height, with a maximum of ± 70 mm.

The 2 brackets for the support of the conveyor channel are screwed directly on the frame with some spacers, using the cavities on the profile. The channel is fastened on the brackets using the cavities or the holes on the side of the profile.

BS3D system is composed of a two legged frame with aluminum profile and is thought for double tracks conveyors.

The feet at the base of the frame are in polyamide and are adjustable in height, with a maximum of ± 50 mm.

Standard feet don't have the anti vibrations rubber, but they can be predispose with the holes to fix the conveyor to the ground. A model with wheels with brake is also available: this model hasn't got regulation.

The 2 brackets for the support of the conveyor channel are screwed directly on the frame, using the cavities on the profile. The channel is fastened on the brackets using the cavities or the holes on the side of the profile.

For the realization of support with a height not included in this standard range or with a wider regulation, please contact our Technical Department

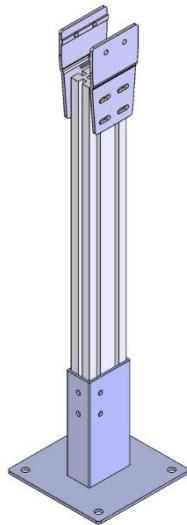
**Composition:**

Frame in aluminum profile 80x40

SFC30 : 2 pieces

DS2010A : 4 pieces

BPSZ8040 : 1 piece

Order Code: BIS3

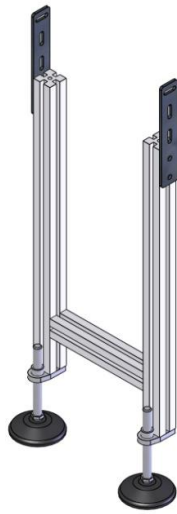

Composition:

- Frame in aluminum profile 40x40 mm : 2 pieces
- SFC40 : 2 pieces
- BPSA4040 : 3 pieces
- PS4040 : 2 pieces
- PSR100

Order Code: BIS3D

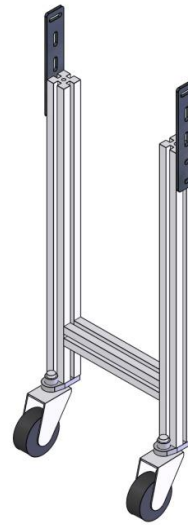

Composition:

- Frame in aluminum profile 40x40 mm : 2 pieces
- SFC40 : 2 pieces
- BPSA4040 : 2 pieces
- PS4040 : 3 pieces
- RP80 : 2 pieces

Order Code: BIS3DR

BIS3	BIS3D
<p>X = required chain level</p>	<p>X = required chain level Y = L+123 mm (where L is the axle spacing between the tracks)</p>



HOW TO WRITE THE ORDER CODES FOR CONVEYOR SUPPORT SYSTEMS	
Description	Order Code
Support type	BIS1D BIS1DR BIS2D BIS2DR BIS3 BIS3D BIS3DR BIS5D BIS5DR
Material (if available)	Stainless Steel: X
Chain plan height	H followed from the height measure of the chain plan in mm
Axle spacing between the tracks	L follows by the axle spacing between the tracks

Example:

S5D support in stainless steel with height 915 mm for single channel
Cod: BIS5D-X-H915



Conveyor support accessories

Material : Reinforced polyamide
Colour : Black
Packaging : 8 pieces

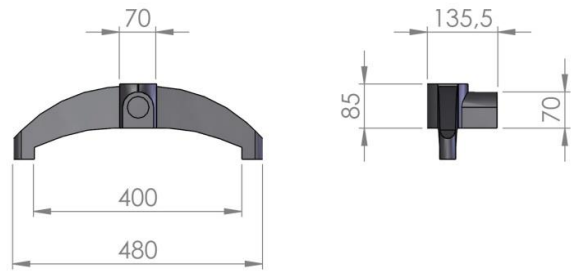

Order Code: GF70

Channel fastening brackets

Material : Sanded aluminum
Packaging : 10 Pieces

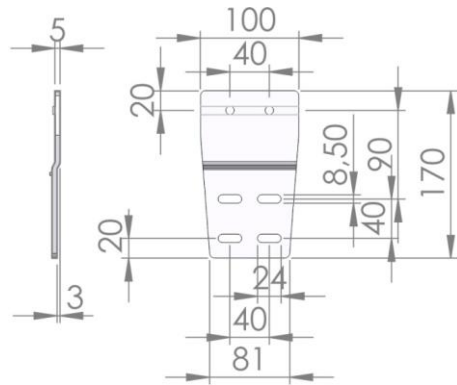

Order Code: SFC30

Material : Stainless steel
Packaging : 10 Pieces

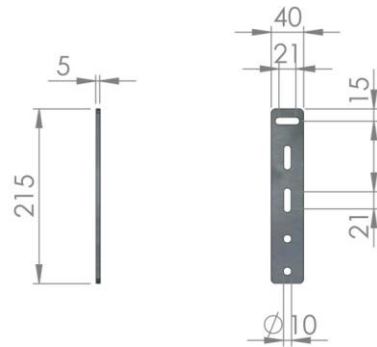

Order Code: SFC40

Fastening brackets spacers

Material : Anodized aluminum
Packaging : Custom cut into bars

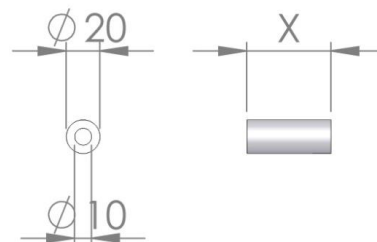

Order Code: DS2010A

Support feet

Material : Galvanized steel and Polyamide
 Colour : Black
 Packaging : 10 pieces

Order Code: PSR100

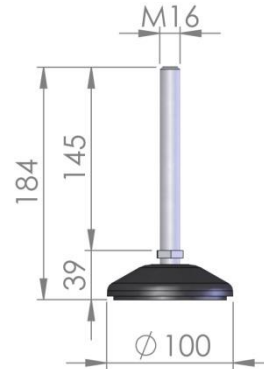

Material : Galvanized steel and Polyamide
 Colour : Black
 Packaging : 10 pieces

Order Code: PSR60

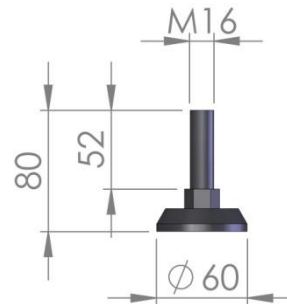

Material : Galvanized steel and rubber
 Packaging : 1 piece

Order Code: RP80

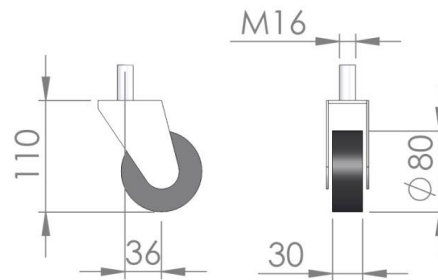



Galvanized steel bases

Material : Galvanized steel
Length : 1 piece

Order Code: BPSZ8040

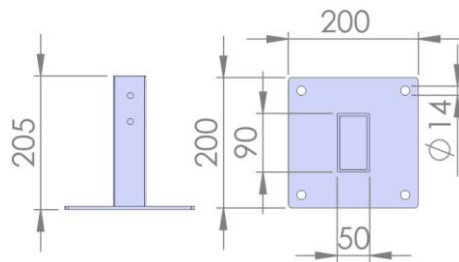

Sanded aluminum bases

Material : Sanded aluminum
Packaging : 10 Pieces

Order Code: BPSA4040

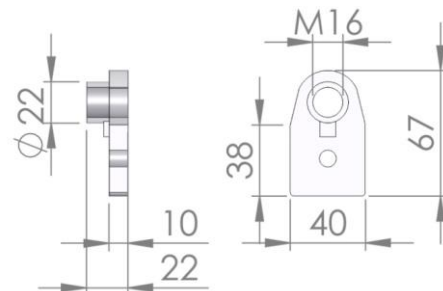

Material : Sanded aluminum
Packaging : 10 Pieces

Order Code: BPSA8040

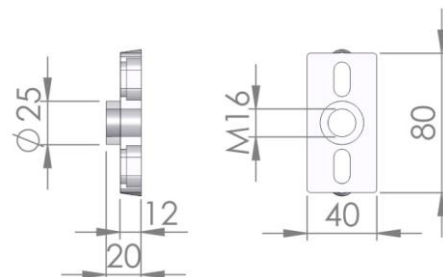



Support profiles

Material : Anodized aluminum
Length : 3÷6 meters in bars

Order Code: PS4040

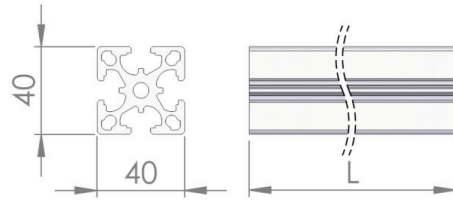

Material : Anodized aluminum
Length : 3÷6 meters in bars

Order Code: PS8040

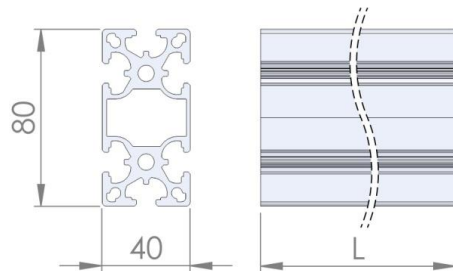

Profile cap

Material : Polyamide
Colour : Black
Packaging : 10 pieces

Order Code: TC4040

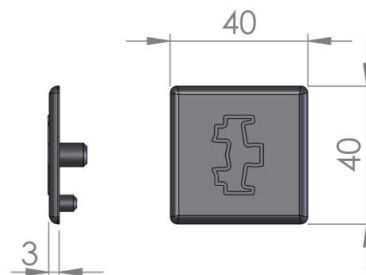

Square nuts

Material : Galvanized steel
 Stainless steel
Packaging : 100 pieces

Order Code: DRM4/5/6/8

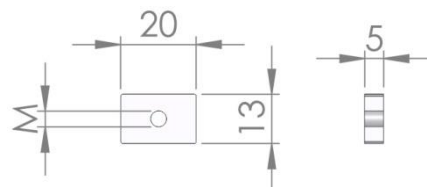



Connecting angles

Material : Sanded aluminum
Packaging : 10 Pieces

Order Code: AC3525

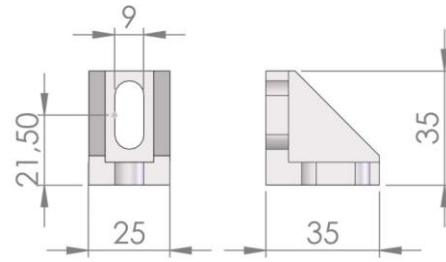

Material : Sanded aluminum
Packaging : 10 Pieces

Order Code: AC3525C

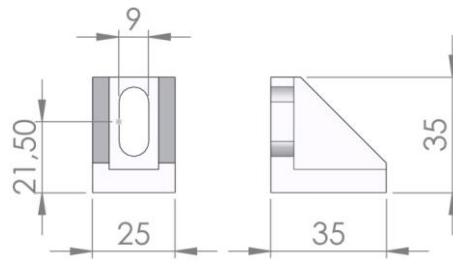

Material : Sanded aluminum
Packaging : 10 Pieces

Order Code: AC3570

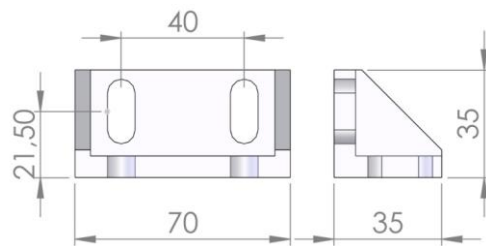



Material : Anodized aluminum
Packaging : 10 Pieces

Order Code: AC3070

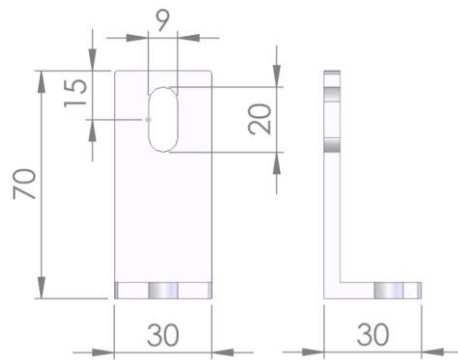

Material : Sanded aluminum
Packaging : 10 Pieces

Order Code: AC4387

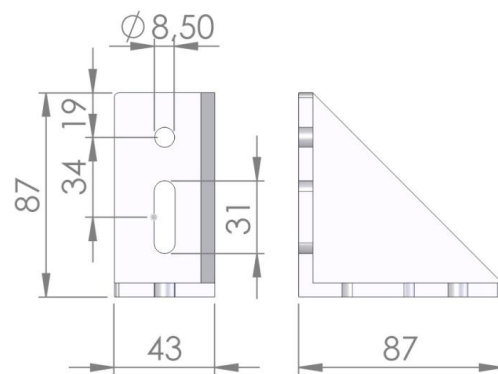



Profile joining plate

Material : Sanded aluminum
Packaging : 10 Pieces

Order Code: PG4040

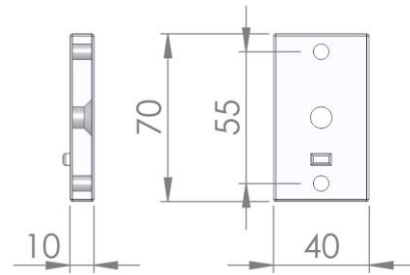

Material : Sanded aluminum
Packaging : 10 Pieces

Order Code: PG8040

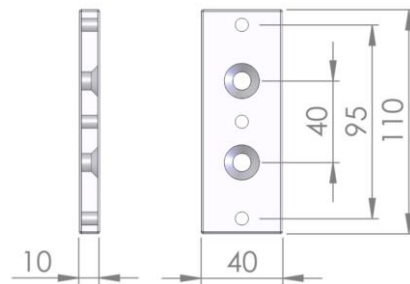

Material : Galvanized steel
Packaging : 10 Pieces

Order Code: PG630/45/60/90

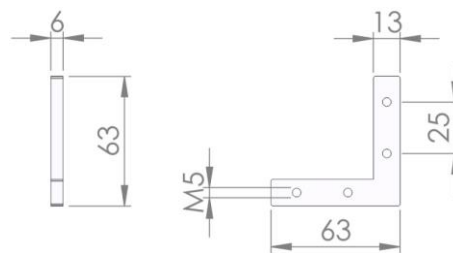



Stainless Steel BIFLEX

For lines in which the conveyor touches the naked product or where it is necessary that the conveyor channel not have slots or for specific requests, a version of Biflex made in stainless steel is available, complete with all the accessories.

Please specify the type of material required for the line when placing the order:

- the simple stainless steel line has a smooth side without slots made in steel sheet, but it still has aluminum spacers inside. The same is true for the curves, end drives and end returns, which all have standard components in aluminum in their interiors.
This type of line is indicated as BIX
- the washable stainless steel line, instead, is made with stainless steel components created specifically for lines that must be washable. In addition to the smooth side without slots, the spacers inside are all made in round stainless steel bars. Even the end motor drives and return ends are all made so that the conveyor can be washed completely.
Washable stainless steel version consider also sliding curves custom made, but a corresponding for disk curves isn't available.
This type of line is indicated as BIW

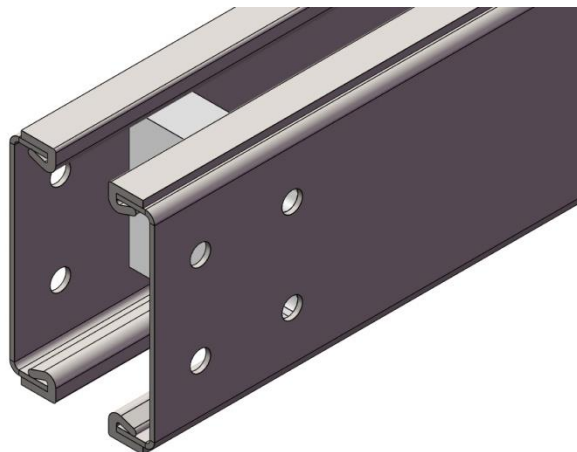

Biflex Chain guide channel in stainless steel

Material : Stainless steel
 Length : 3 m

Order Code: BIX
BIW

